



HEWLETT  PACKARD

**HP-41C**  
**Alphanumeric Programmable**  
**Scientific Calculator**  
**SERVICE MANUAL**

00041-90008

© HEWLETT-PACKARD COMPANY  
1000 N.E. Circle Blvd., Corvallis, Oregon 97330

Printed July 1979

# Contents

Section	Page	Section	Page
<b>I GENERAL INFORMATION</b>		<b>IV TROUBLESHOOTING AND TESTING</b>	
1-1. Introduction .....	1-1	4-1. Introduction .....	4-1
1-4. Description .....	1-1	4-5. Initial Preparation .....	4-2
1-8. Identification .....	1-2	4-7. Diagnostic Test .....	4-2
<b>II THEORY OF OPERATION</b>		4-9. Repair and Test .....	4-5
2-1. Functional Description .....	2-1	4-12. Auxiliary Tests .....	4-14
2-5. CPU .....	2-1	4-13. Low-Level Detection Test .....	4-14
2-17. ROM .....	2-4	4-16. Battery Test .....	4-14
2-19. Data Storage .....	2-4	<b>V SERVICE MODULE</b>	
2-21. Liquid Crystal Display .....	2-4	<b>VI REPLACEABLE PARTS</b>	
2-26. Display Driver .....	2-4	6-1. Introduction .....	6-1
2-32. Power Supply .....	2-5	6-4. Ordering Information .....	6-1
2-40. Keyboard .....	2-6	<b>A MEMORY/APPLICATION MODULE TEST</b>	
2-42. Input/Output Ports .....	2-6	A-1. Introduction .....	A-1
2-45. Audible Alarm .....	2-6	A-3. Description .....	A-1
2-47. System Operation .....	2-6	A-8. Identification .....	A-1
<b>III DISASSEMBLY AND REASSEMBLY</b>		A-10. Diagnostic Test .....	A-1
3-1. Case Separation .....	3-1		
3-2. I/O Assembly Replacement .....	3-2		
3-3. Display Disassembly and Replacement ..	3-2		
3-4. Logic PCA Replacement .....	3-5		
3-5. Case Reassembly .....	3-6		

## Illustrations

Figure	Title	Page	Figure	Title	Page
1-1.	HP-41C Keyboard and Memory .....	1-1	4-4.	Contacts on Keyboard PC Board .....	4-15
2-1.	HP-41C Block Diagram .....	2-2	4-5.	Contacts at I/O Port .....	4-15
2-2.	Display Character Structure .....	2-4	4-6.	Component Location Diagram for Logic PCA .....	4-17
2-3.	System Timing .....	2-7	4-7.	HP-41C Schematic Diagram .....	4-17
4-1.	Key Assignments for Service Module ...	4-1	6-1.	HP-41C Exploded View .....	6-3
4-2.	Test Calculator .....	4-5			
4-3.	Service Clamp .....	4-5			

## Tables

Table	Title	Page
1-1.	Specifications .....	1-2
2-1.	Signal Names .....	2-1
2-2.	Coding of I/O Ports .....	2-6
4-1.	Recommended Tools .....	4-1
4-2.	Detailed Diagnostic Test Procedure .....	4-6
4-3.	CPU Test Procedures .....	4-12
4-4.	Power Supply Troubleshooting Procedure .....	4-13
4-5.	Logic PCA Replaceable Parts .....	4-17
5-1.	Summary of ET-11966 Service Module Operation .....	5-3
6-1.	HP-41C Replaceable Parts .....	6-2
A-1.	Module Specifications .....	A-1

GENERAL INFORMATION

THEORY OF OPERATION

DISASSEMBLY AND REASSEMBLY

TROUBLESHOOTING AND TESTING

SERVICE MODULE

REPLACEABLE PARTS

MEMORY/APPLICATION MODULE TEST



# General Information

## 1-1. INTRODUCTION

1-2. This service manual contains information necessary to troubleshoot and repair the HP-41C calculator. Appendix A gives information for testing plug-in memory modules and application modules. Service information for other plug-in accessories is presented in separate manuals.

1-3. The manual is divided into six sections, which give:

- A general description of the HP-41C calculator (section I).
- An explanation of how it works (section II).
- Information for disassembly and reassembly (section III).
- Steps for troubleshooting and testing the calculator (section IV).
- A description of the plug-in service module (section V).
- A list of replaceable parts (section VI).

## 1-4. DESCRIPTION

1-5. The HP-41C is a handheld, alphanumeric programmable scientific calculator with input/output capabilities and a continuous memory. (See figure 1-1.) It also features a user-definable keyboard for personalized usage.

1-6. The HP-41C system is designed for accurate service. The use of a plug-in service module gives a reliable check of the entire calculator and provides a visual output of its diagnosis, virtually eliminating troubleshooting for most repairs.

1-7. The specifications of the HP-41C are summarized in table 1-1. A detailed description of the proper use of this calculator is contained in the *HP-41C Owner's Handbook and Programming Guide*. Operating conditions which result in an error message are presented in appendix E of the handbook.

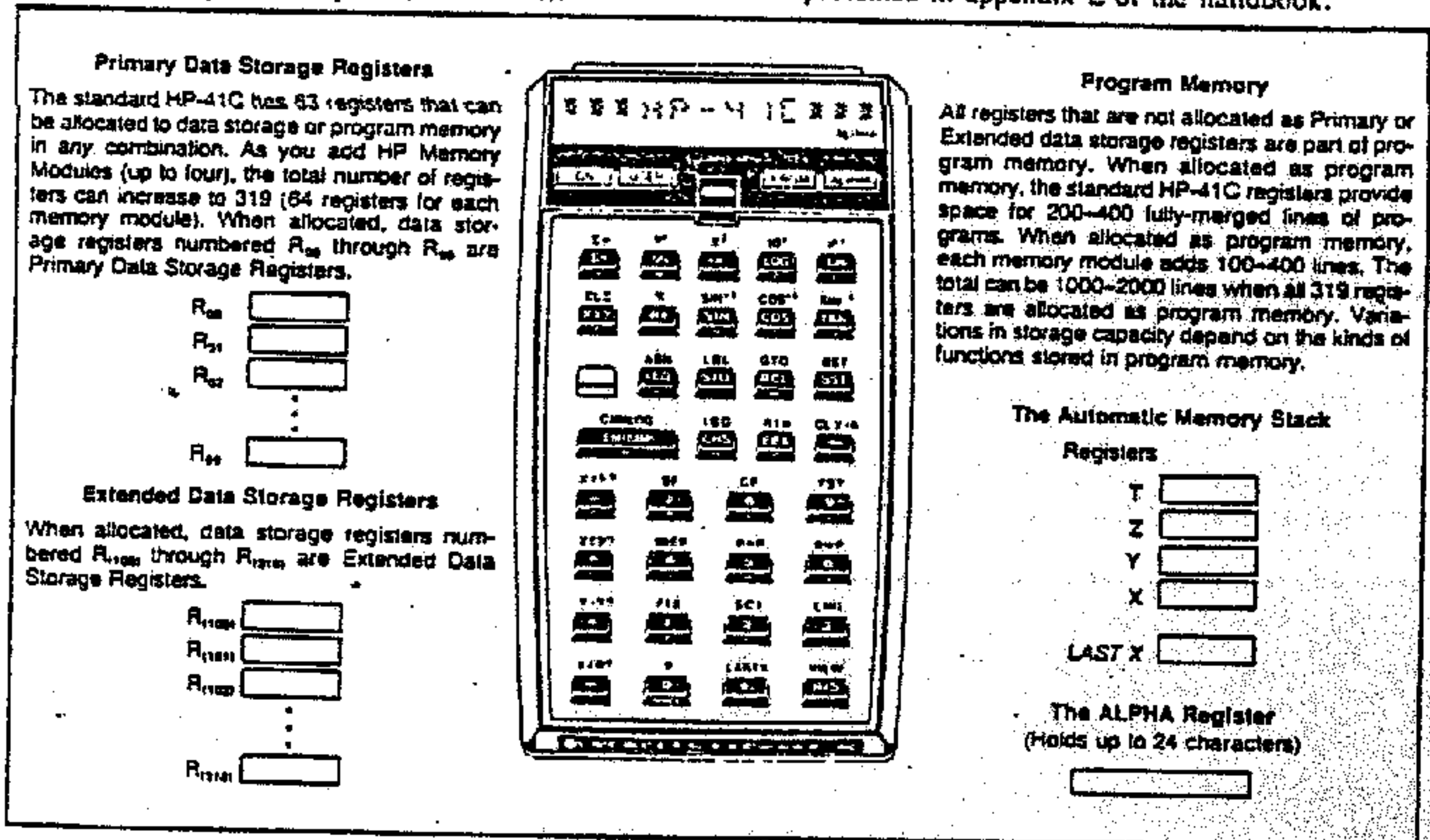

Figure 1-1. HP-41C Keyboard and Memory

Table 1-1. Specifications

Physical Properties	Display
<ul style="list-style-type: none"> <li>Length: 14.27 centimeters (5.62 inches).</li> <li>Width: 7.86 centimeters (3.09 inches).</li> <li>Height: 3.33 centimeters (1.31 inches).</li> <li>Weight: 205 grams (7.2 ounces) with batteries.</li> </ul>	<ul style="list-style-type: none"> <li>Liquid crystal display has 12 characters positions and 12 annunciator words.</li> <li>Each character position consists of 17 segments, including 3 punctuation segments.</li> <li>Numbers are shown with maximum of 10 digits, or an 8-digit mantissa and 2-digit exponent.</li> <li>Displayed numbers are rounded to the last displayed digit; calculations are performed internally with at least 10 digits.</li> <li>Range of displayed numbers is <math>\pm 1.0000000 \times 10^{-10}</math> to <math>\pm 9.9999999 \times 10^{99}</math> plus zero.</li> <li>Alphanumeric characters include A through Z, a through z, 0 through 9, plus 37 special characters, some of which can be obtained only by using special plug-in accessories.</li> </ul>
<p><b>Power</b></p> <ul style="list-style-type: none"> <li>Batteries: Four 1.5V, size N batteries, replaceable by the user.</li> <li>Battery current, worst case:                             <ul style="list-style-type: none"> <li>50 mA (RUN mode).</li> <li>1 mA (STANDBY mode).</li> <li>50 <math>\mu</math>A (SLEEP mode).</li> </ul> </li> </ul>	
<p><b>Temperature</b></p> <ul style="list-style-type: none"> <li>Operating: 0° to 45°C (32° to 113°F).</li> <li>Storage: -20° to 65°C (-4° to 149°F).</li> </ul>	

1-8. IDENTIFICATION

1-9. The serial number of the calculator is used for identification and determination of warranty status. It is located on the bottom case at the upper right-hand corner, adjacent to the I/O ports. Its format is described below:

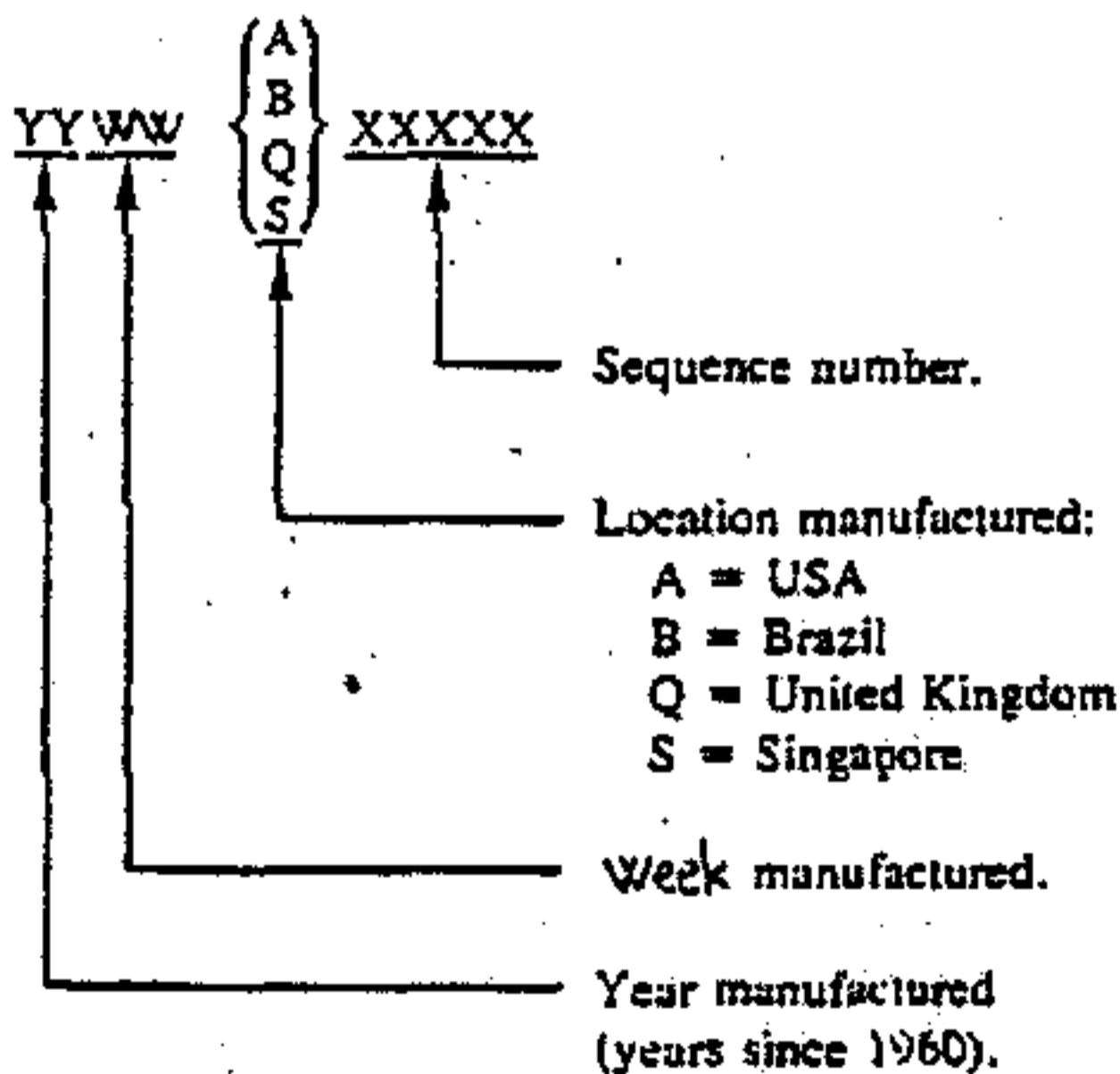



# Theory of Operation

## 2-1. FUNCTIONAL DESCRIPTION

2-2. The HP-41C design (see figure 2-1) is based on 11 primary electrical components:

- a. The CPU (central processing unit) integrated circuit.
- b. Three ROM (read-only memory) integrated circuits.
- c. Five data storage (D/S) integrated circuits.
- d. The display driver hybrid circuit.
- e. The power supply integrated circuit.

The power supply is a conventional bipolar integrated circuit (IC); all other IC's employ CMOS (complementary metal-oxide-semiconductor) circuitry, enabling the calculator to have a continuous memory.

2-3. Manual input to the calculator is through a 39-position keyboard; visual output is through an LCD (liquid crystal display) with 12 character positions. Four input/output (I/O) ports provide additional access to the calculator. An audible alarm is also featured.

2-4. The system operates serially on 56-bit information, with data represented as binary-coded-decimal (BCD) numbers, and instructions and addresses as binary numbers. The timing of the system is referenced to the  $\Phi 2$  signal from the CPU. (Signal names are listed in table 2-1). A bit time (the period during which a single bit of data is transferred) is the time interval between the trailing edges of two successive  $\Phi 2$  pulses. A word time consists of 56 bit times (0 through 55) and is the basic interval for information transfer.

## 2-5. CPU

2-6. The CPU is the core of the calculator. It consists of eight basic sections, which are described in the following paragraphs:

- a. Timing generator.
- b. Instruction processor.
- c. Address, status, and flag registers.
- d. Data registers.
- e. Arithmetic processor.
- f. Conditional test logic.
- g. Power control logic.
- h. Keyboard interface.

2-7. **Timing Generator.** This section of the CPU includes logic for generating three timing signals ( $\Phi 1$ ,  $\Phi 2$ , and SYNC) used to synchronize the system IC's. The nominal oscillator frequency of 1440 kHz is reduced by a factor of 4 to produce a system operating frequency between 343 and 378 kHz, which is the frequency of the  $\Phi 1$  and  $\Phi 2$  pulses. The  $\Phi 1$  pulses have a width of approximately one-eighth of a period; the  $\Phi 2$  pulses are twice as wide. The  $\Phi 1$  pulses lead the  $\Phi 2$  pulses by approximately one-fourth period.

Table 2-1. Signal Names

SIGNAL	DESCRIPTION
B3	I/O port coding
B4	I/O port coding
DATA	Data line
DPWO	Display power on/off line
F1	Input flag line
FO	Flag line to alarm
GND	Ground
ISA	Instruction/address line
KC0 thru KC4	Keyboard column lines
KR0 thru KR7	Keyboard row lines
LLD	Low level detect line
L1V thru L3V	Display voltages
OSI	Display oscillator
POR	Power-on reset line
PWO	Power on/off line
SYNC	Timing/information line
V <sub>BAT</sub>	Battery voltage
V <sub>CC</sub>	System voltage
V <sub>C1</sub>	Voltage control input line
V <sub>C0</sub>	Voltage control output line
$\Phi 1$	Timing line
$\Phi 2$	Timing line

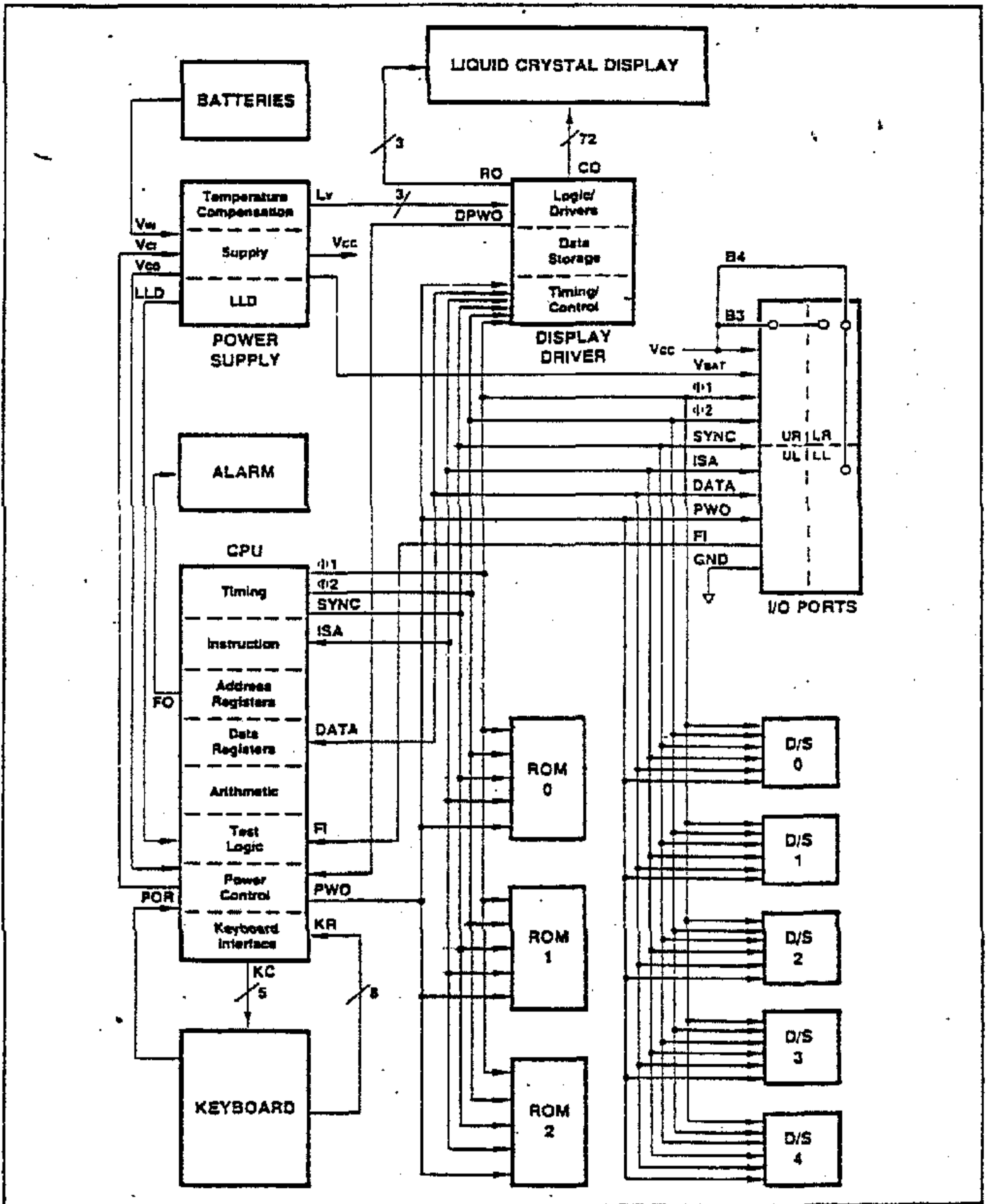

Figure 2-1. HP-41C Block Diagram



**2-8.** The SYNC signal, consisting of a 10-bit pulse during bit times 44 through 53, has two main functions. The first SYNC pulse generated by the CPU following power-on is used to initialize the timing circuits of the system IC's. Subsequently, the presence or absence of the SYNC pulse indicates whether information on the ISA line is an instruction or an address. (The SYNC pulse is suppressed when the system is controlled by a plug-in accessory.) Additionally, when the CPU timing circuit is disabled (STANDBY and SLEEP modes), the CPU sets the SYNC line equal to the DPWO signal from the display driver for access at the input/output ports.

**2-9.** The CPU also includes a status counter which generates a four-bit pulse at a digit time specified by the CPU instruction processor. It is used to set conditions within the CPU.

**2-10. Instruction Processor.** The CPU instruction processor decodes instructions arriving on the ISA line and directs the various sections of the CPU to perform the necessary operations. If system control is transferred to a plug-in accessory, the instruction processor does not decode instructions until system control is again returned to the CPU.

**2-11. Address, Status, and Flag Registers.** This section of the CPU contains:

- a. A 16-bit program counter used for the current instruction address.
- b. Four 16-bit address registers used for return branching from subroutines.
- c. A 14-bit system status register.
- d. An 8-bit flag register used to store eight system flags (which are all equal). The CPU sequentially transmits the flag conditions on the FO line during each entire word time. By periodically setting and resetting the flags, the CPU can generate a signal to activate the audible alarm.

**2-12. Data Registers.** The CPU data registers consist of:

- a. Three 56-bit working registers (A, B, and C) used for arithmetic operations by the CPU arithmetic processor. The C-register is connected to the DATA line and is used for data transfer operations with data storage.
- b. Two 56-bit memory registers (M and N) used for temporary information storage.
- c. One 8-bit register (G) used for the storage of portions of the C-register contents.

**2-13. Arithmetic Processor.** This CPU section consists of a 56-bit, serial, binary/BCD adder/subtractor which performs arithmetic operations on all or part of the data in the A-, B-, and C-registers. It also contains the logic for controlling data transfers among the CPU registers.

**2-14. Conditional Test Logic.** The conditional test logic is used to test the state of various one-bit flags, including 14 input flags (FI0 through FI13) on the FI line from the I/O ports, the low battery voltage signal from the power supply, and the adder carry flag, key flag, status bits, and arithmetic pointers within the CPU. The outcomes influence branching at the CPU address registers.

**2-15. Power Control Logic.** The power control logic in the CPU exercises the primary control of the system power mode. (The display driver determines the power mode when the CPU is inactive.) In response to signals received on the POR, ISA, DPWO, and  $V_{CO}$  lines and from the keyboard interface section of the CPU, the power control logic determines the system voltage level provided by the power supply and enables or disables the system IC's. Control signals are sent on the  $V_{CI}$  and PWO lines.

**2-16. Keyboard Interface.** The keyboard interface logic in the CPU is connected to the keyboard by five column lines (KC0 through KC4) and eight row lines (KR0 through KR7). In RUN power mode the logic scans the column lines, bringing each line low once every word time. When a key is pressed (connecting the corresponding row and column lines), the row line is brought low by the column line at the same rate, setting the key flags in the CPU power control logic and conditional test logic. The logic loads into the two keyboard interface buffers the four-bit codes for the row line and column line. The resultant eight-bit code is used by instructions in ROM to determine what operation is to be performed. Instructions in ROM cause the system to ignore the keyboard for 40 ms after a key is pressed and 5 ms after a key is released. These delays negate the effects of key bounce, which causes multiple entries.

**2-17. ROM**

2-18. The ROM (read-only memory) consists of three IC's each containing 4096 10-bit microprogrammed instructions that are used by the CPU to execute the specified operations. Most operations require instructions stored in more than one ROM. However, only one ROM is accessed at any time. When the ROM address register in each ROM receives a 16-bit address on the ISA line, the decoder in each ROM uses the four most significant bits of the address to determine if the addressed location is in that ROM. The proper ROM is enabled and transmits the addressed instruction on the ISA line; the remaining ROM's are disabled. A timing circuit in each ROM synchronizes the ROM's operation with the system timing using the  $\Phi 1$ ,  $\Phi 2$ , and SYNC signals from the CPU.

**2-19. Data Storage**

2-20. Data storage (D/S) consists of five IC's, each containing 16 56-bit registers. Only one D/S IC is enabled at any time. When the decoder in each IC receives a D/S register location on the ISA or DATA line in conjunction with a data transfer instruction on the ISA line, the enabled D/S IC executes the instruction using the indicated register; the remaining IC's are disabled. A timing circuit in each IC synchronizes the D/S operation with the system timing.

2-21. The 16 registers in D/S 0 are used internally for the X, Y, Z, T, LAST X, and ALPHA registers, as well as for maintaining the internal status information. The registers in the remaining four D/S IC's are accessible to the user for storing data and programs.

**2-22. Liquid Crystal Display**

2-23. The display is a 12-character, liquid crystal display (LCD). Each character position has 14 digit segments, 3 punctuation marks, and 1 annunciator space which are defined by three row lines (common to all characters) and six column lines. (See figure 2-2.) The entire display constitutes a 3-row by 72-column matrix which is activated by the display driver.

2-24. A liquid crystal material between the upper and lower metalized glass surfaces produces a visible contrast between a character segment and the surrounding area when the voltage potential between the corresponding row and column lines is at least 3V (at 25°C). At lower voltages the contrast decreases.

No-visible contrast is produced for a voltage potential of approximately 1V. Optimum performance requires the continuous application of an alternating potential whose magnitude determines segment turn-on.

2-25. In order for the display to maintain proper contrast over a temperature range of 0° to 45°C, the peak drive voltage to the LCD must have an average decrease of 20 mV for each degree of temperature increase. This temperature compensation is provided by the power supply circuit.

**2-26. Display Driver**

2-27. The display driver performs three functions required to operate the LCD: timing and control, data storage, and display logic and drivers.

2-28. The timing and control section processes instructions arriving on the ISA line, directs the flow of data into the proper display data storage registers, and provides system timing information to the driver section (utilizing the incoming PWO signal and internal status conditions).

2-29. The data storage registers allocate 10 bits of storage for each of the 12 character positions in the display. For each position one of these bits controls the annunciator word; the remaining bits represent the character and punctuation at the position.

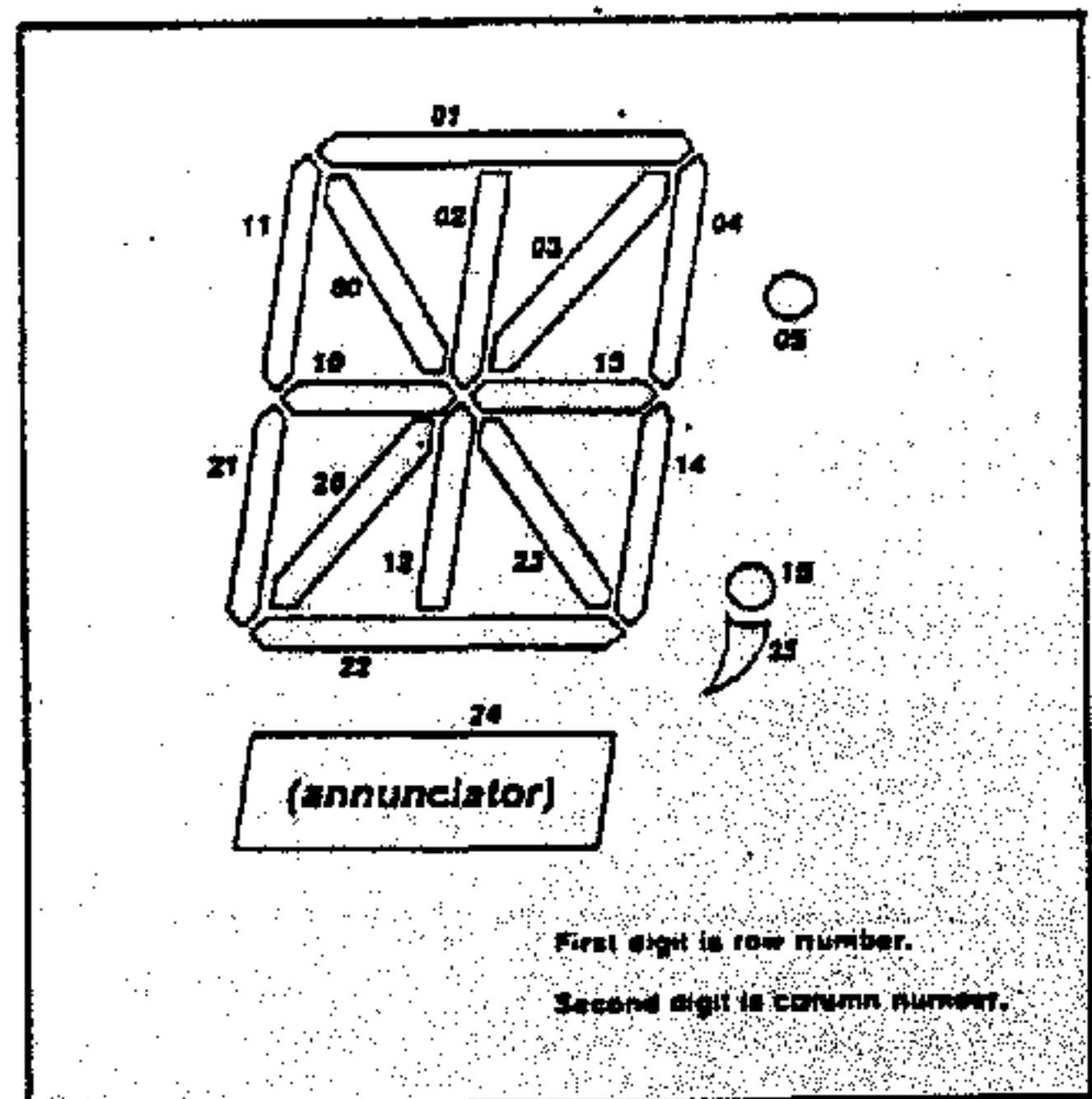

Figure 2-2. Display Character Structure

2-30. Display logic encodes each character in the data storage registers into the six appropriate column signals and stores them in the corresponding drive registers. Using the three temperature-compensated voltages from the power supply, the driver circuitry provides 72 column signals (12 characters, each with six columns) to the LCD according to the information stored in the 72 driver registers, and 3 different row signals, one on each of the three LCD row lines. Each of these signals has a complex, rectangular waveform and is continuously present while the display is active. The row and column signals are structured such that each LCD segment that is "off" experiences an alternating 1V potential; each segment that is "on" has a similar type of signal except that a 3V peak potential exists during one-third of the cycle. Thus each LCD segment is continuously driven by an alternating signal (equal to the potential difference between the corresponding row and column signals) with the peak potential determining segment turn-on. (Previous LED displays have had digit segments being activated for approximately 1 percent of the display cycle, with no voltage applied for the remaining interval.) The 3V peaks are staggered so that at any instant only one row has segments being turned on.

2-31. The driver section also includes a timing circuit and clock. This circuitry synchronizes the driver signals and causes the display to be refreshed approximately 90 times per second. When the incoming PWO signal from the CPU is high (RUN mode), the timing circuit uses the SYNC signal from the CPU as a timing reference. When the PWO signal is low and the display is to be active (STANDBY mode), the DPWO output line to the CPU is set high and the internal driver clock synchronizes the driver signals for a period up to approximately 10 minutes. When the PWO signal is low and the display is inactive (SLEEP mode), the DPWO output is set low.

### 2-32. Power Supply

2-33. Four replaceable 1.5V, size N batteries connected in series are the standard source of power for the HP-41C. Three diodes (CR1, CR5, and CR6, figure 4-7) protect against reverse polarity and provide isolation for the batteries and other power sources (such as in a plug-in accessory). A storage capacitor (C1) temporarily supplies power to maintain the system memory while the calculator is off and the batteries are being changed.

2-34. The power supply circuit consists of a low-power bipolar IC and discrete components which perform all voltage-control functions for the system: system voltage supply and regulation, supply and temperature compensation of the LCD voltages, low battery voltage detection (LLD), and system reset.

2-35. Two selectable voltage levels are available from the power supply. While the display is active (RUN and STANDBY power modes), a voltage converter circuit produces a regulated output of 6V (at  $V_{CC}$ ). When the display is inactive (SLEEP power mode), the voltage output is approximately 1V less than the battery voltage and is not regulated.

2-36. The determination of the correct system voltage is made by the CPU, which sets the appropriate signal on the  $V_{CI}$  line to the power supply: a current signal (at approximately 0.7V) selects the regulated 6V supply; a grounded signal disables the regulator, selecting the unregulated battery voltage. As the regulated supply is being activated, a differential amplifier in the power supply circuit compares the supply voltage to a reference voltage and generates a momentary ground signal on the  $V_{CO}$  line to the CPU when the supply voltage reaches 6V.

2-37. Three temperature-compensated voltage levels (nominally 1.1, 2.2, and 3.3V) are provided to the display driver by the power supply. A transistor in the power supply IC responds to changes in the ambient temperature, producing the  $-20 \text{ mV}/^\circ\text{C}$  output variation required by the display.

2-38. The power supply circuit monitors the input voltage level by comparing it with a reference voltage generated internally. A differential amplifier in the IC senses whether the voltage has fallen below 4.2V at the IC, and if so, it grounds the LLD line connected to the CPU.

2-39. The reset circuit initializes the CPU whenever the CPU is in RUN mode and a decrease occurs on the  $V_{CC}$  line. This circuit provides a method for restarting the CPU if it "locks up" in a condition in which the system does not respond to keyboard or peripheral input. With the system in RUN mode, capacitor C9 (see figure 4-7) is charged and transistors Q1 and Q2 are off. If  $V_{CC}$  drops, C9 turns on Q1, which then turns on Q2. Transistor Q2 draws sufficient current to pull PWO low even though the CPU tries to hold it high. This is sensed by the CPU, which interrupts its operation and returns to STANDBY mode.

## 2-40. Keyboard

2-41. Data is manually entered into the calculator through the keyboard, consisting of 35 function keys and 4 operating keys mounted in the top case. Each key is located above a dome-shaped "snap disk" which is mounted over the keyboard PC. The 39-position keyboard matrix is connected to the CPU by five column lines and eight row lines. When a key is pressed, the center of the disk snaps down and makes electrical contact between the corresponding row and column lines.

## 2-42. Input/Output Ports

2-43. The four input/output ports on the HP-41C allow the user to expand the calculator's capacity and to have it interact with external components. Electrical contact is provided by a flexible printed-circuit strip mounted on a contact frame. The system lines which are accessible at the I/O ports are:

- a.  $\Phi 1$  (timing line).
- b.  $\Phi 2$  (timing line).
- c. SYNC (timing/information line).
- d. ISA (instruction/address line).
- e. DATA (data line).
- f. PWO (power on/off line).
- g. FI (input flag line).
- h.  $V_{BAT}$  (battery voltage).
- i.  $V_{CC}$  (system voltage).
- j. GND (ground).
- k. B3 (I/O port coding).
- l. B4 (I/O port coding).

2-44. The B3 and B4 lines from each of the four ports are wired differently at each port so that each plug-in accessory will have a unique identification code. (Refer to table 2-2).

Table 2-2. Coding of I/O Ports

I/O PORT LOCATION	I/O PORT NUMBER	B3 CONTACT	B4 CONTACT
Upper Left	1	Open	Open
Upper Right	2	$V_{CC}$	Open
Lower Left	3	Open	$V_{CC}$
Lower Right	4	$V_{CC}$	$V_{CC}$

## 2-45. Audible Alarm

2-46. The audible alarm is a piezoelectric device, which converts an alternating electrical signal into a mechanical vibration. The signal is generated by the CPU and transmitted to the alarm on the FO line. Because physical stress on the piezoelectric device can induce excessive voltage at FO, diodes CR3 and CR4 (see figure 4-7) assure that the voltage across the alarm does not exceed approximately 6V.

## 2-47. SYSTEM OPERATION

2-48. To the user, the HP-41C appears to have two power conditions: "on" and "off." However, there are actually three power modes: RUN, STANDBY, and SLEEP. The use of these three modes provides extended battery life by minimizing the current drain.

2-49. In RUN mode the CPU actively controls the flow and processing of data and the display presents information to the user. In STANDBY mode the system timing and data processing are disabled, while the display continues to operate. The calculator appears to be "on" in RUN and STANDBY modes. In SLEEP mode all functions, including display, are disabled and the calculator appears to be "off," although a low-level current maintains the system's memory.

2-50. The following paragraphs describe system power modes and IC conditions and responses corresponding to a typical sequence of operations.

### 2-51. Initial Condition

2-52. The calculator is in SLEEP mode when the PWO signal from the CPU and the DPWO signal from the display driver are both low. The low PWO signal disables the ROM and D/S IC's to prevent them from responding to spurious signals. The power supply is inactive, leaving the system voltage set at the battery voltage level. The display and CPU are inactive. Only a minimum current supply is required to maintain the system's memory.

### 2-53. Power ON Response

2-54. When the power ON key is pressed, the CPU senses the ground signal at its POR input and generates a current on the  $V_{CC}$  line to the power supply. (The

same result is obtained by having a plug-in accessory momentarily set the ISA line high.) The power supply then provides the regulated 6 V and puts a low signal on the  $V_{CC}$  line to the CPU when the voltage is at the proper level. The CPU initiates its timing signals ( $\Phi 1$ ,  $\Phi 2$ , and SYNC) defining bit time 52, and sets PWO high at bit time 54 to enable the ROM and D/S IC's and the display driver. At this time the calculator is temporarily in RUN mode. The CPU checks the status of the system, checks the I/O ports, and sets the display. A transistor circuit (Q3, R4, and R5; see figure 4-7) uses the  $\Phi 2$  signal to set the DATA line low at the start of each bit time interval.

2-55. After the necessary operations have been performed, the CPU sets PWO low at the next bit time 53 to disable the ROM and D/S IC's and to cause the display driver to set DPWO high and start its clock. The CPU clock stops at bit time 55, the SYNC line is set high, and the keyboard column lines are all set low. The display remains active, with timing provided by its internal clock. The calculator is in STANDBY mode.

2-56. Key Entry Response

2-57. When a key is pressed in STANDBY mode, the corresponding keyboard row line to the CPU is brought low through the column line. The CPU responds by initiating the system timing signals (defining bit time 52) and setting PWO high at bit time 54 to enable the ROM and D/S IC's and to turn off the display driver clock. The CPU begins scanning the five keyboard column lines by sequentially grounding each line for four bit times during each word time. (See figure 2-3.) The CPU loads into its key buffers the two four-bit keycodes corresponding to the key pressed. The CPU also checks the status of the system and the I/O ports.

2-58. The CPU carries out the specified operation by executing a series of instructions contained in ROM. The CPU obtains each instruction from ROM by transmitting the 16-bit address of the instruction over the ISA line during bit times 14 through 29. The ROM containing the address transmits the contents of that location over the ISA line during bit times 44 through 53. (See figure 2-3.)

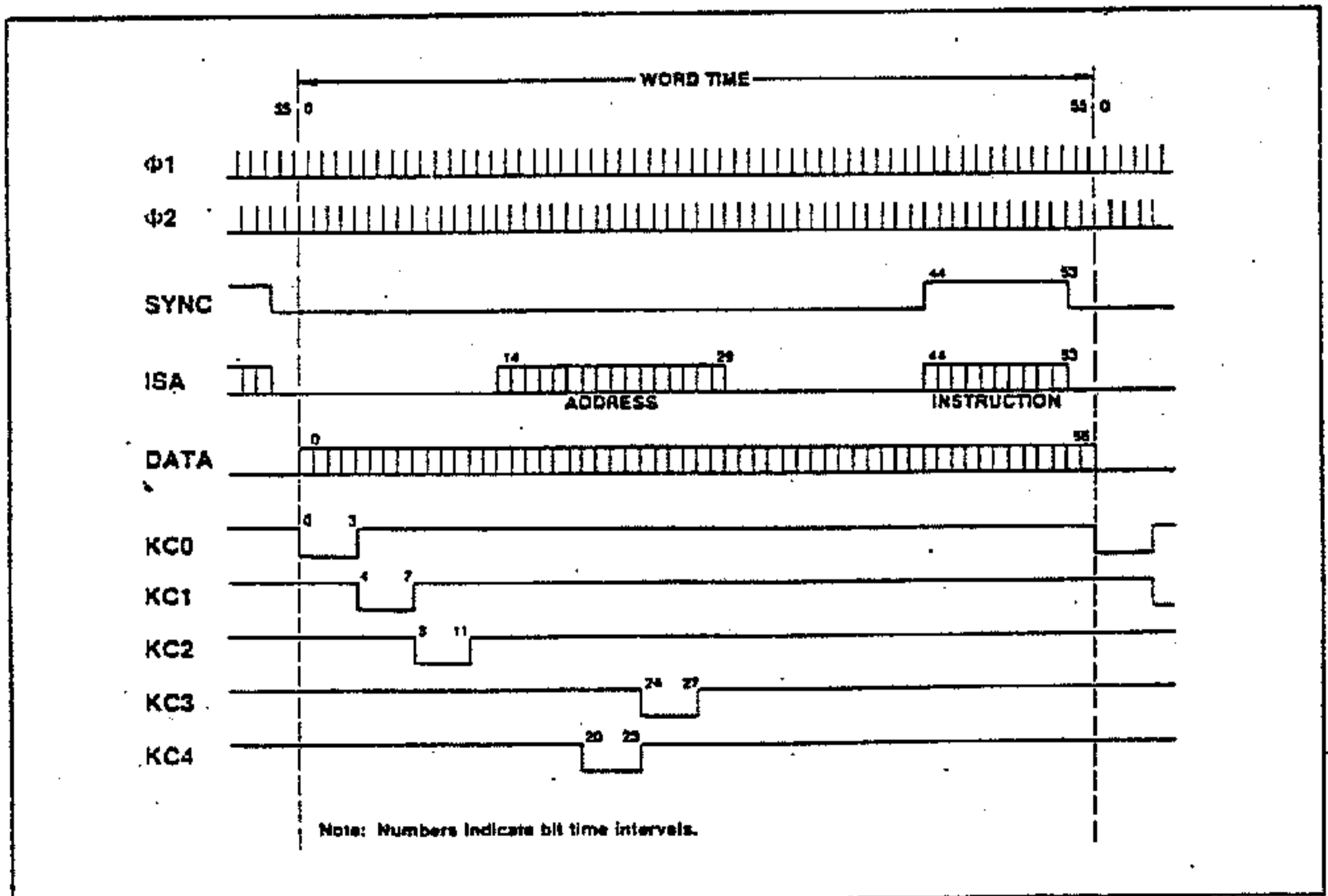

Figure 2-3. System Timing

2-59. If the transmitted ROM contents are an instruction to be executed, the CPU generates a pulse over the SYNC line at the same time that the instruction is being transmitted (bit times 44 through 53). This tells D/S to monitor the instruction to determine whether action (such as data transfer) is required. The CPU executes the instruction during the following word time, and increments its program counter by one to specify the next address.

2-60. If the transmitted ROM contents are an address to be used for branching, the CPU suppresses the SYNC pulse while the address is being transmitted on the ISA line. This prevents D/S from responding to the ISA signal. The CPU transmits this address during the next word time.

2-61. If a ROM instruction specifies a transfer of data, the data is sent over the DATA line during bit times 0 through 55 of the next word time. (See figure 2-3.) The transfer is made serially, least-significant bits first.

2-62. When all specified operations have been performed, the CPU initiates the power-down sequence described in paragraph 2-55, which places the calculator in STANDBY mode.

2-63. If additional keys are now pressed, the calcula-

tor returns to RUN mode, as described in paragraph 2-57.

#### 2-64. Power Off

2-65. If the power ON key is pressed while the calculator is in RUN or STANDBY mode, the POR input to the CPU is brought low through the KCO column line. The CPU returns the calculator to RUN mode (paragraph 2-57) and sets the display driver for immediate turn-off. At the next bit time 53 the CPU sets PWO low to disable the ROM and D/S IC's and the display. The CPU stops its clock at bit time 55, sets the SYNC and keyboard column lines low, and grounds the  $V_{CI}$  line to the power supply. The  $V_{CI}$  signal disables the power circuit, causing the system voltage to drop to the unregulated battery voltage. The calculator is now in SLEEP mode.

2-66. Alternately, if no additional operations are requested within approximately 10 minutes following the beginning of STANDBY mode (paragraph 2-62), the display driver sets DPWO low, turns off the display and deactivates its clock. The CPU responds to the DPWO signal by setting the SYNC line low and grounding the  $V_{CI}$  line to the power supply. This disables the power supply circuit, dropping the system voltage to the unregulated battery voltage. The calculator is left in SLEEP mode.

## Disassembly and Reassembly

The following procedures describe the steps necessary to disassemble and reassemble the HP-41C in order to replace components or assemblies that are faulty. For additional aid, see the exploded view, figure 6-1.

### CAUTION

Ensure that adequate precautions are taken regarding electrostatic protection. Use the antistatic desoldering tool (8690-0227) and work at a bench setup that is electrostatically protected. Otherwise, IC's may be damaged.



### CASE SEPARATION

- a. Remove the battery case by pressing its top edge toward the upper end of the calculator until the case snaps free.
- b. Remove and set aside batteries if the customer has left any in the case.
- c. Remove and discard the four rubber feet from the bottom case by lifting them out with a pointed knife.
- d. Remove the four screws located in the foot recesses using a small Phillips screwdriver.
- e. Lift off the bottom case and center case.

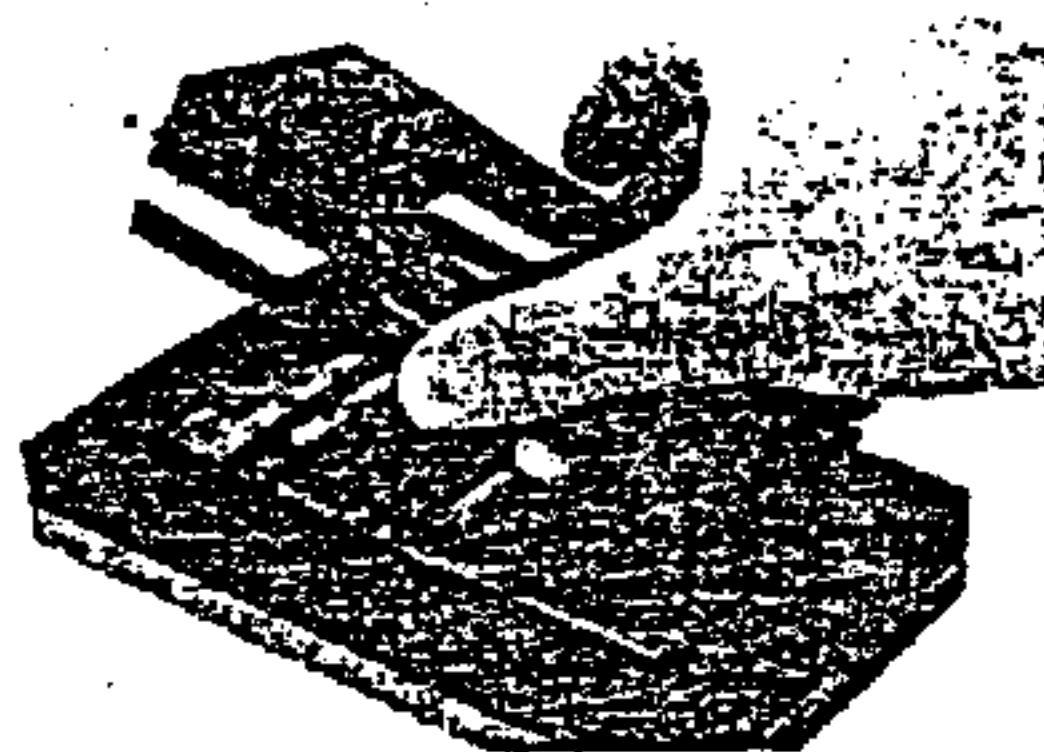
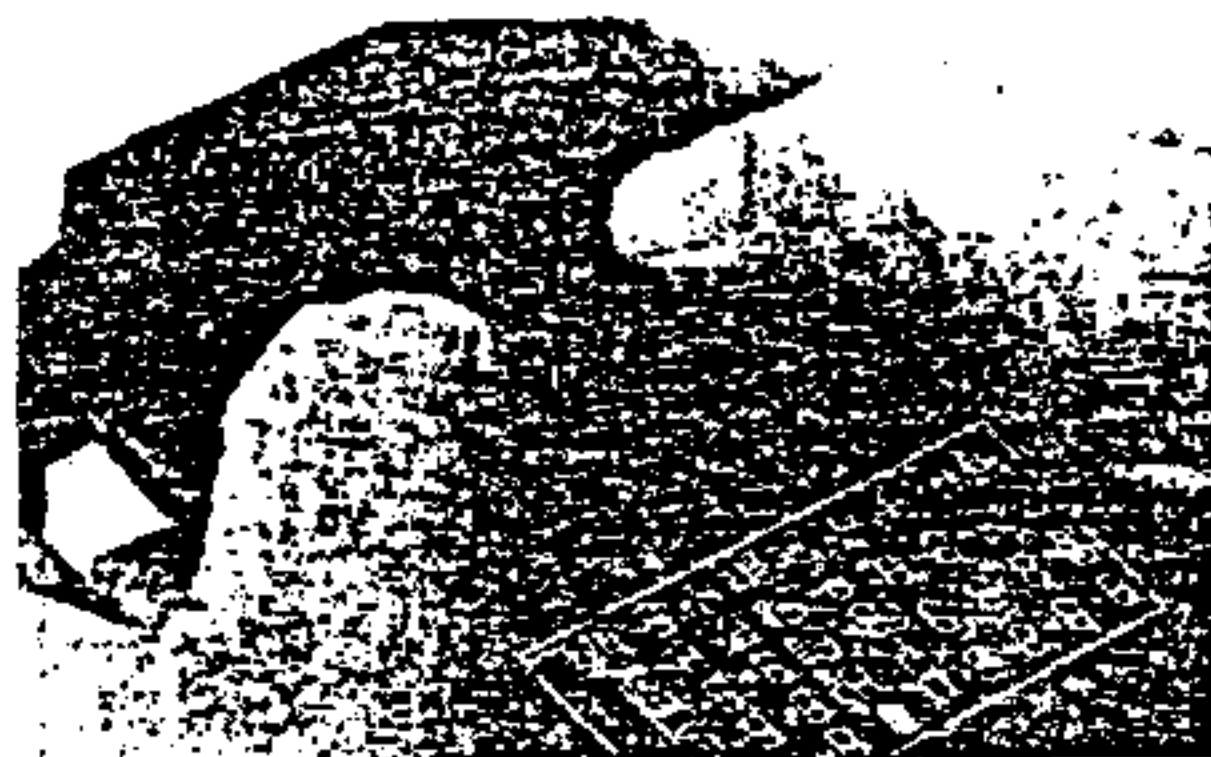

**2****I/O ASSEMBLY REPLACEMENT**

After separating the case (procedure 1):

- a. Remove the I/O contact assembly from the bottom case by lifting it out.
- b. Install the I/O contact assembly in the bottom case by lowering it into position. Be sure that the cross webs on the underside of the connector are located between the tabs on the bottom case. If the cross webs are properly aligned, the bottom of the contact assembly will seat flush on the case with only slight pressure.

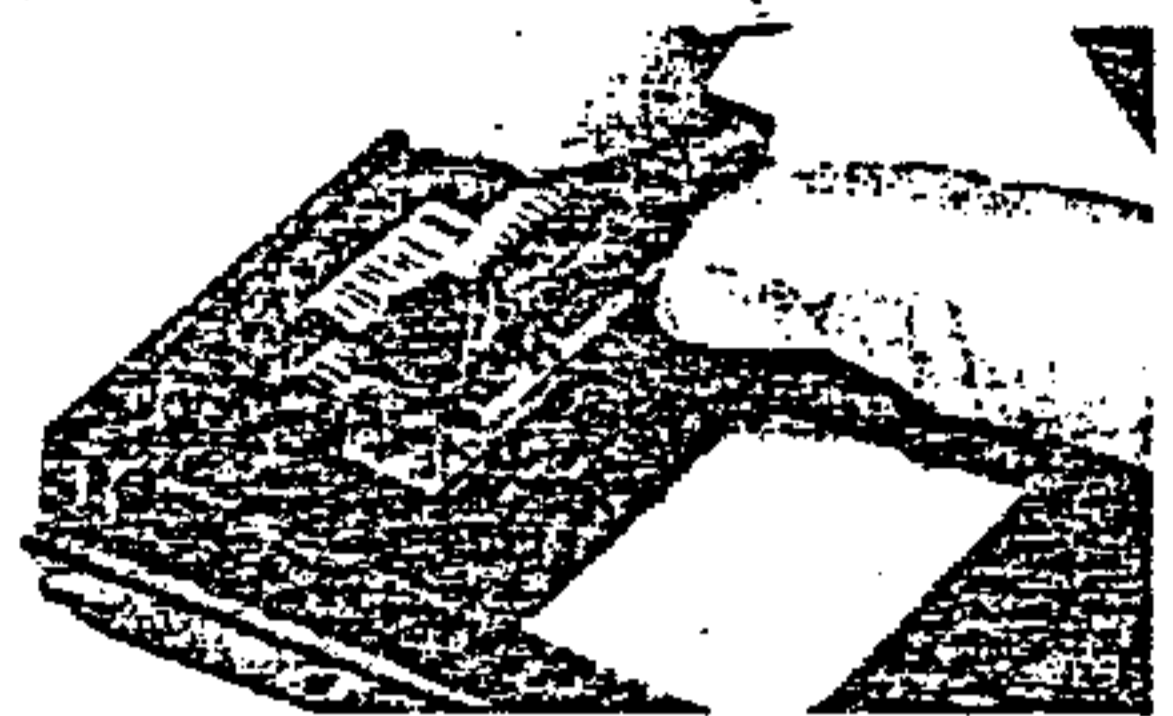
**3****DISPLAY DISASSEMBLY AND REPLACEMENT**

**Note:** If the display assembly is to be replaced as a unit, perform steps a through c and i through l.

**CAUTION**

Wear finger cots (part number 9300-0398) and use care when handling the display assembly. The front and back glass surfaces of the LCD module each have a plastic layer that is easily damaged, and the contact fingers on the display driver PCA are easily damaged.

After separating the case (procedure 1):

- a. Unsolder the contact fingers from the keyboard PCA.

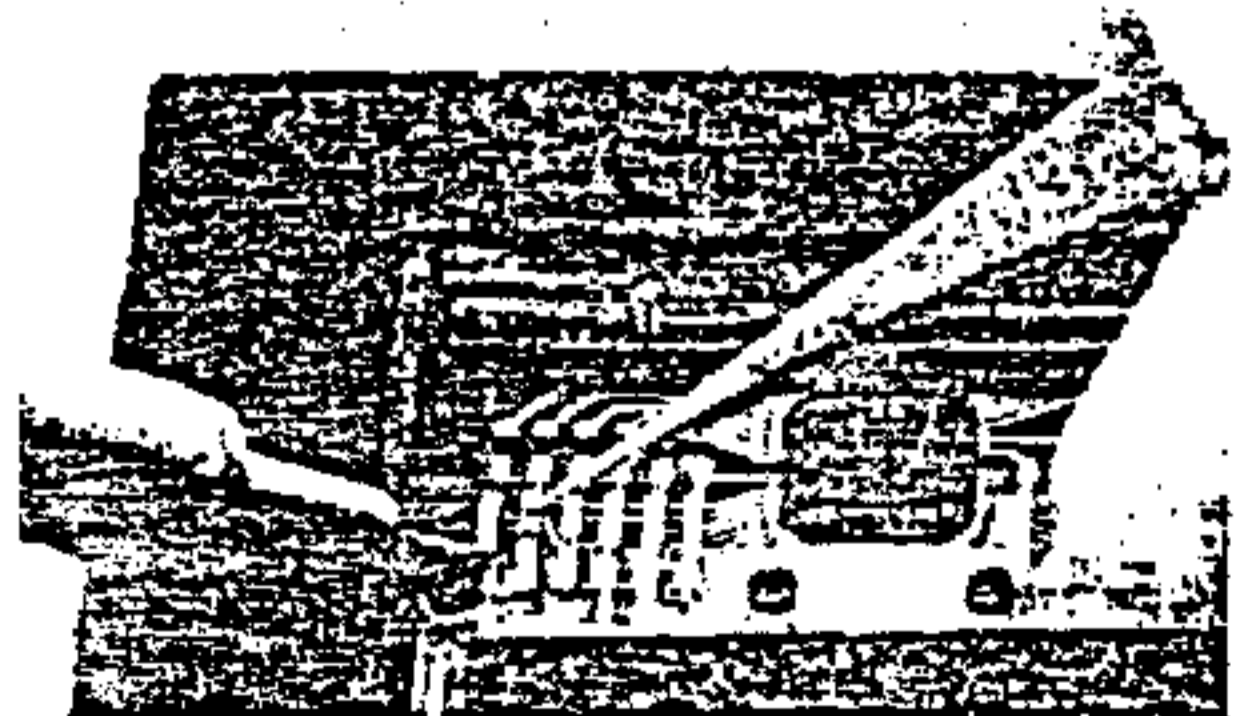



- b. Remove the display shield from the top edge of the display assembly.

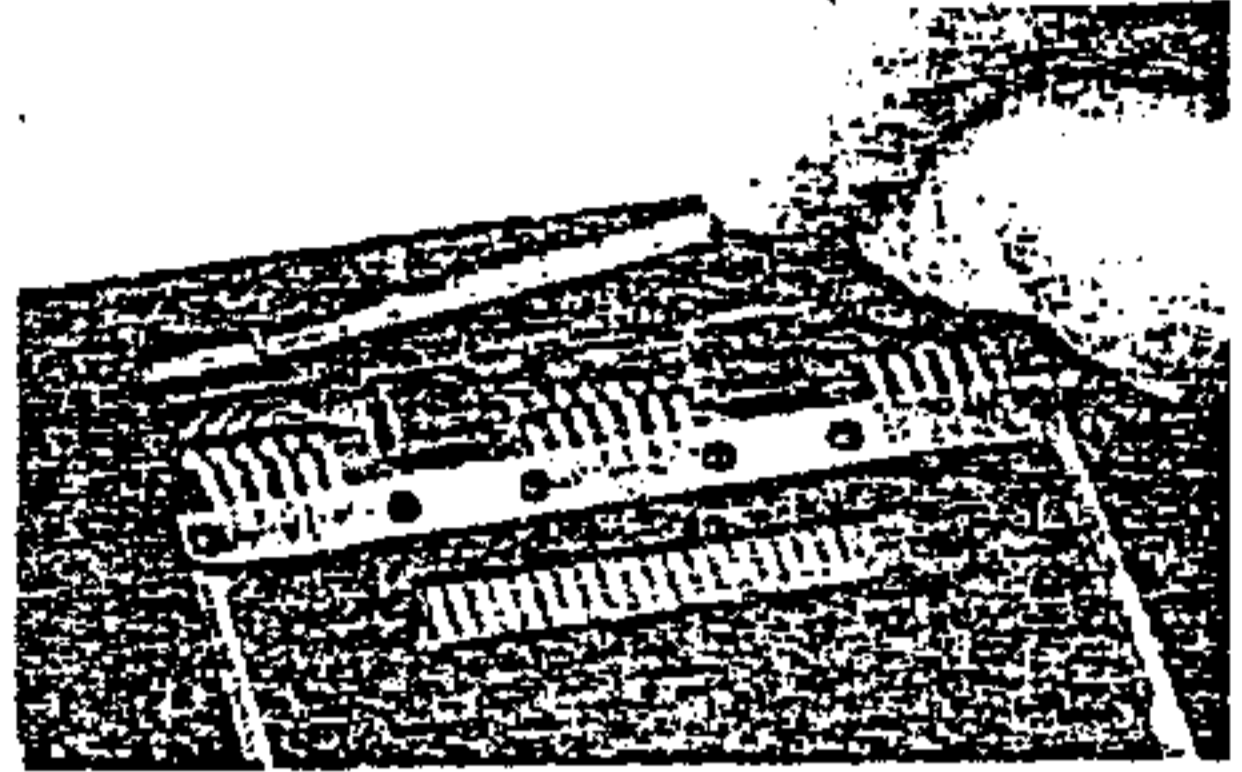

- c. Remove the display assembly from the keyboard assembly by lifting it out top edge first or tapping the inverted assembly on your hand.

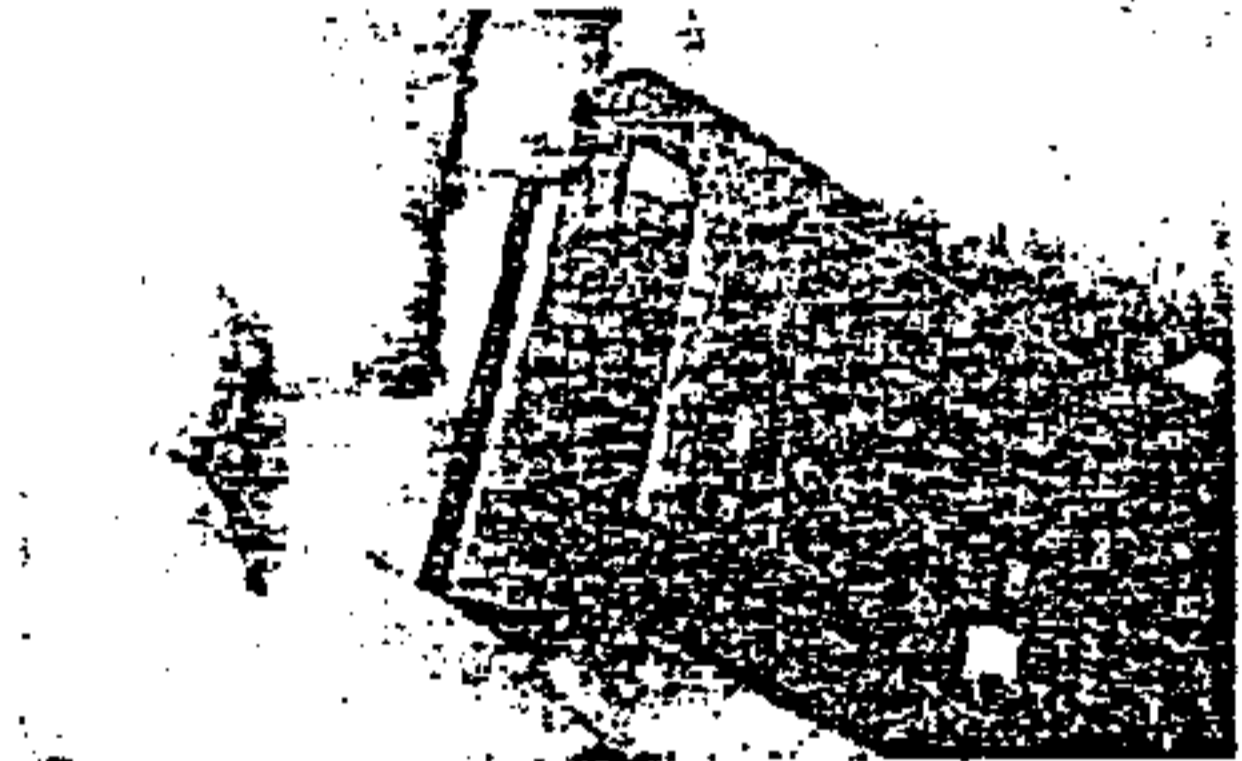

- d. Remove the display clips and insulators from the long edges of the display assembly. Grasp the assembly and firmly pull each clip outward, one at a time.

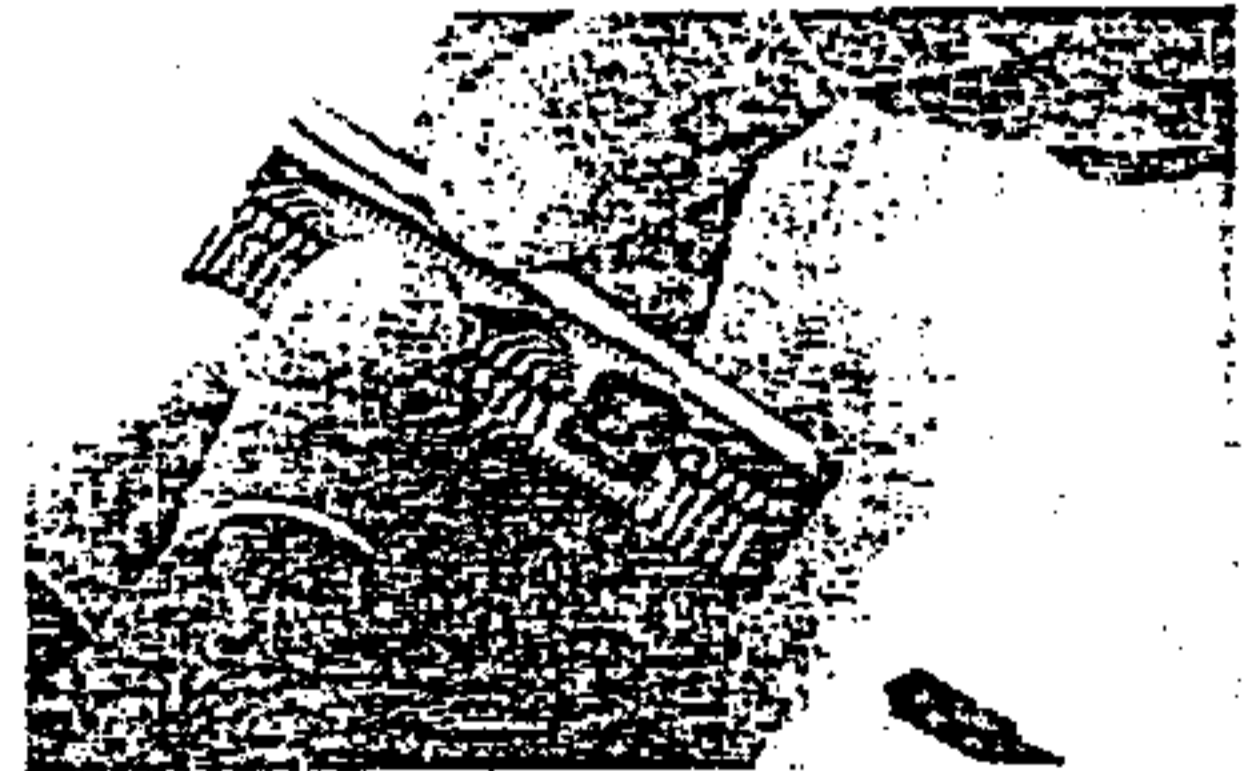

- e. Separate the LCD and display driver by rotating the driver about the pin on the display locator until they separate.

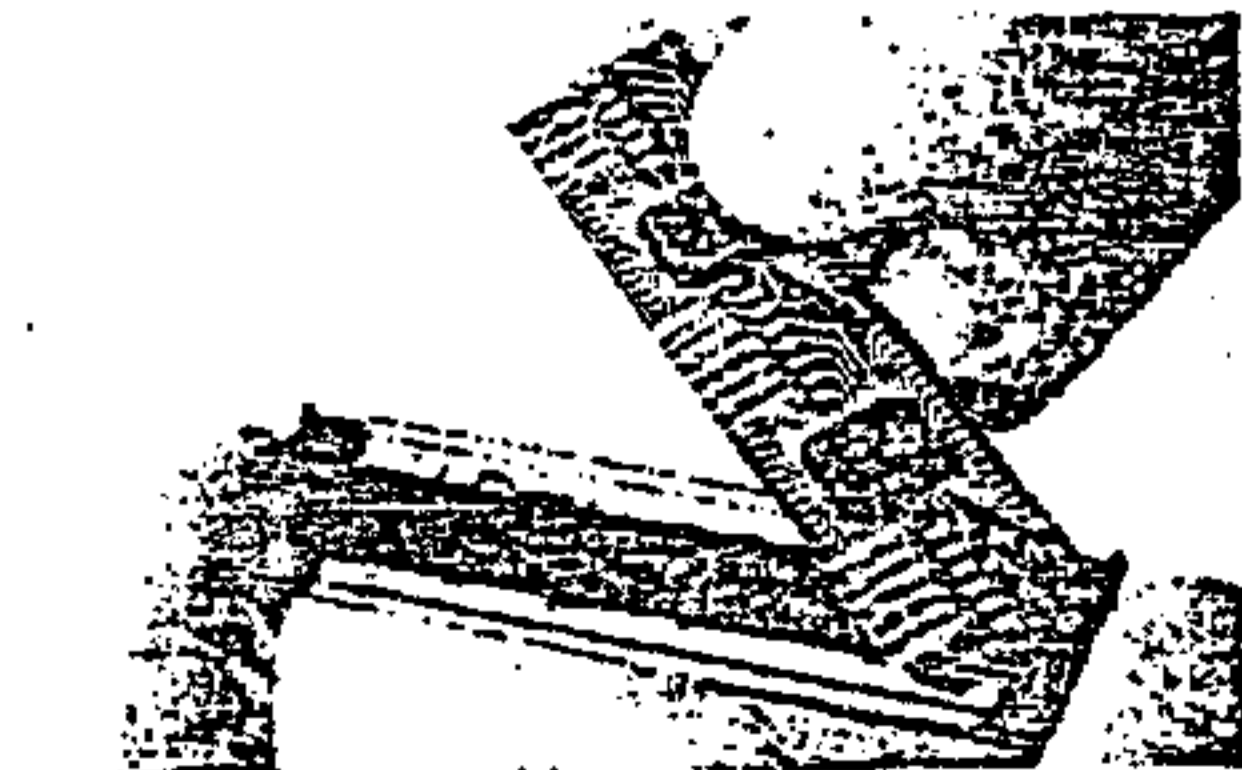

- f. If necessary, replace the display locator or connectors on the LCD module. A strip of adhesive transfer tape holds them to the raised portion of the LCD back surface. After removing the old adhesive, the locator is installed by positioning the end with a gap over the soldered end of the LCD, and then pressing it into place along its entire length. The tab along each connector is centered in the gap in the locator edge; the connector should span all of the contact pads on the LCD. *Do not reuse* a locator and connectors that have been removed from the LCD.
- g. Mount the display driver on the LCD, being sure that the pin on the display locator fits into the hole in the driver. Use flush-cutting snips or a sharp knife to trim off any portion of the pin that protrudes above the surface of the driver.
- h. Install an insulator and clip along each edge of the display assembly. Secure the upper edge first. First place the insulator along the edge so that the flap covers the surface of the display driver; then slide the clip into place from the end of the assembly. The curl in the edge of each clip should be on the display driver side.
- i. Clean the LCD surface, if necessary. Use a cotton swab or soft cloth moistened with isopropyl alcohol. *Do not* use an abrasive cloth that could scratch the plastic surface.
- j. Install the display assembly into the keyboard assembly. Be sure the contact fingers fit over the edge of the keyboard PCA as the bottom edge of the display is lowered into position, then press the top edge into place.
- k. Solder the contact fingers to the keyboard PCA. Be sure that the display assembly is fully seated.
- l. Install the display shield over the top edge of the display assembly. The ridges on the shield should face toward the bottom-case location.

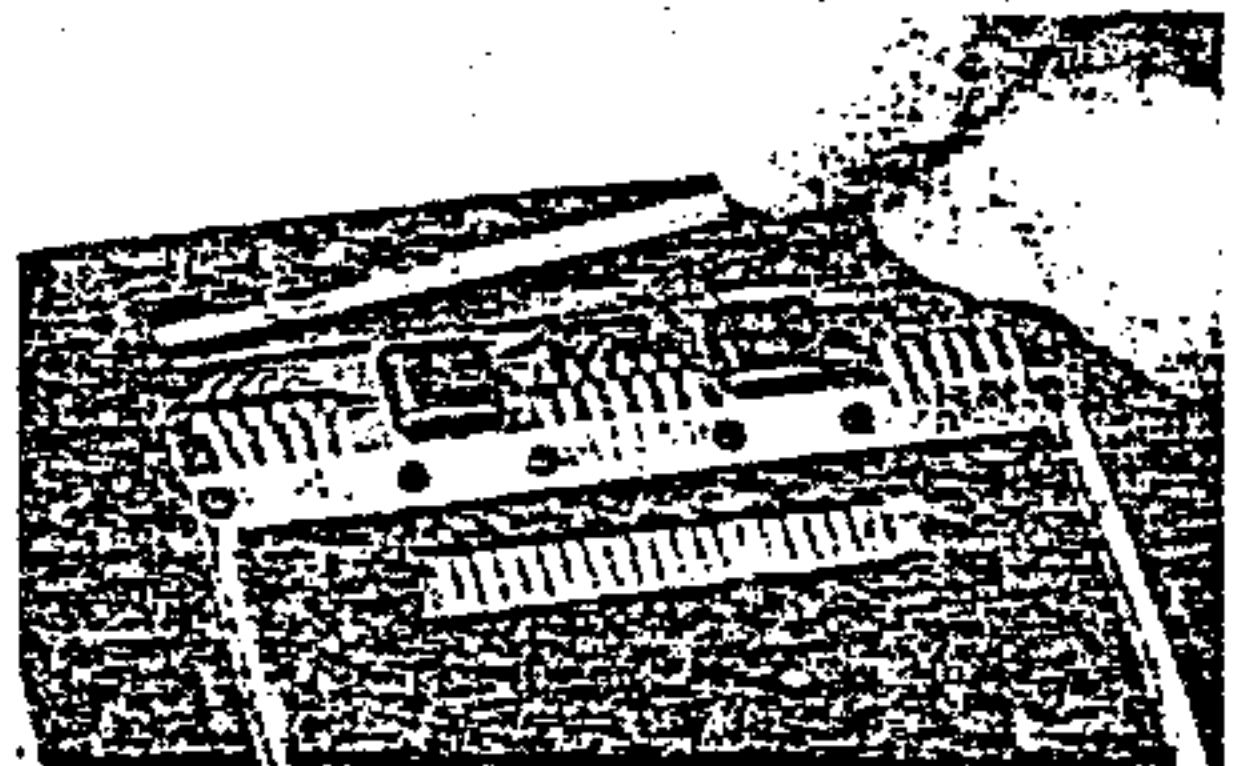
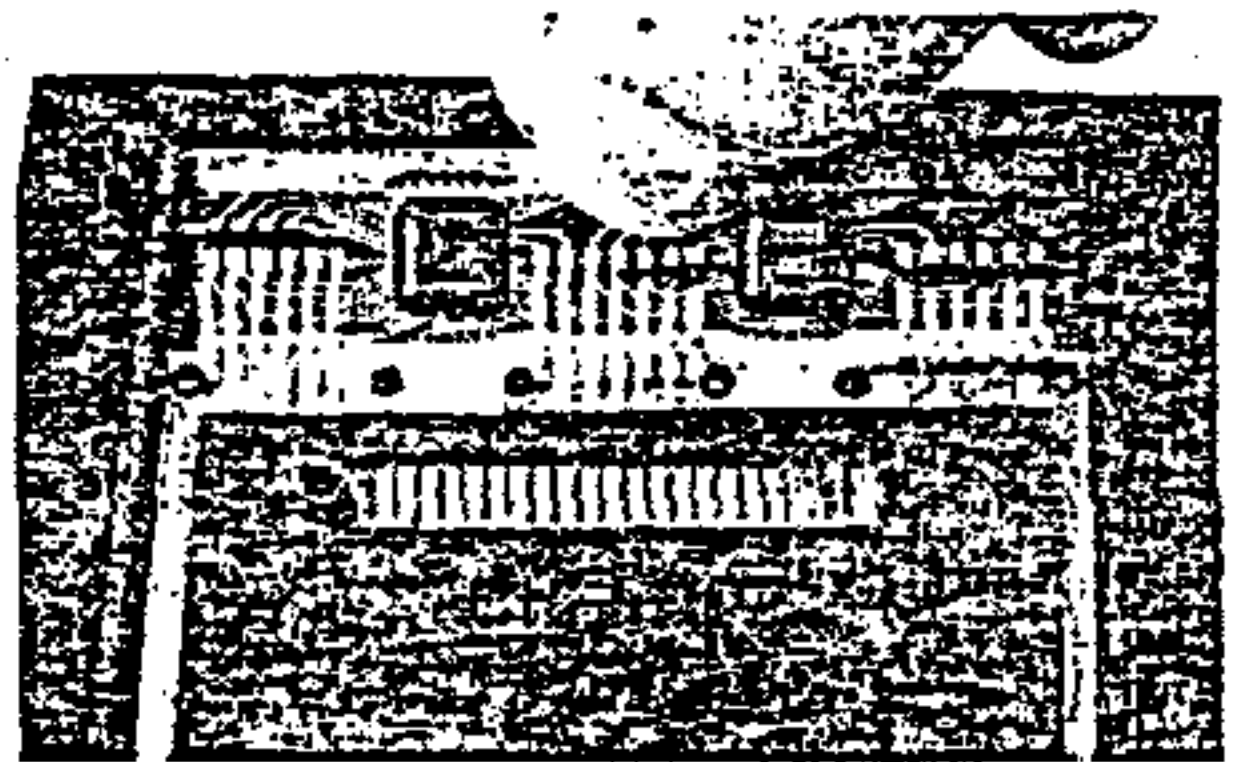
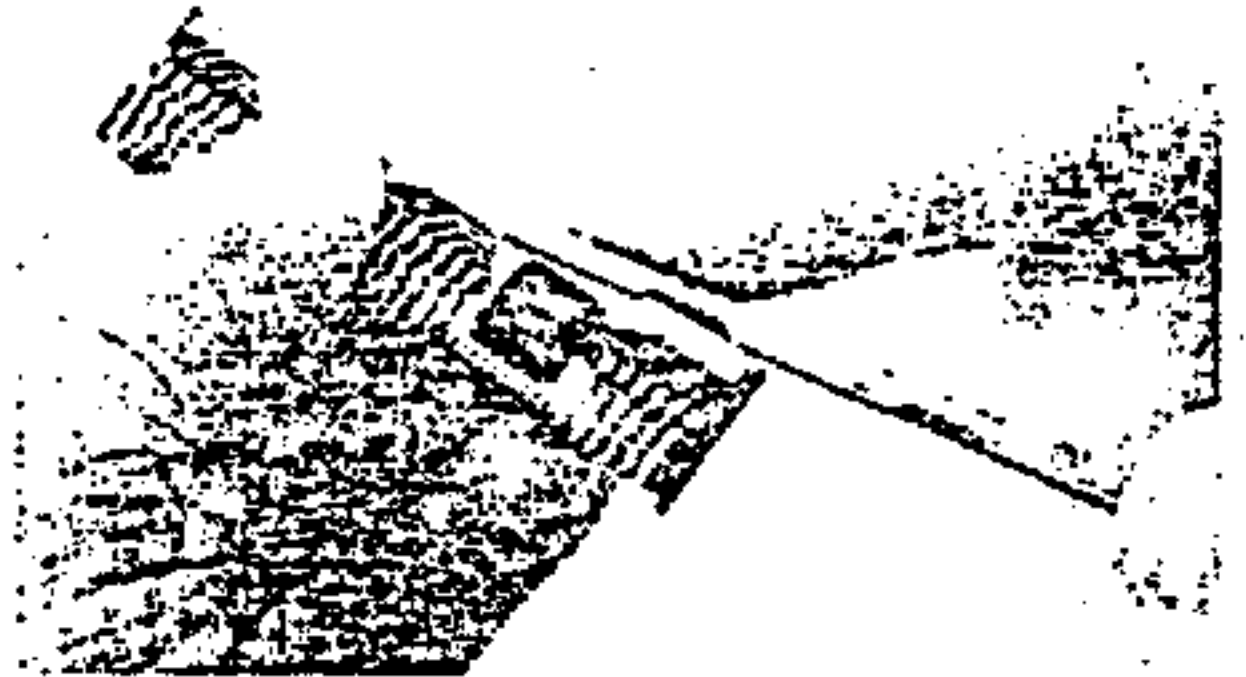
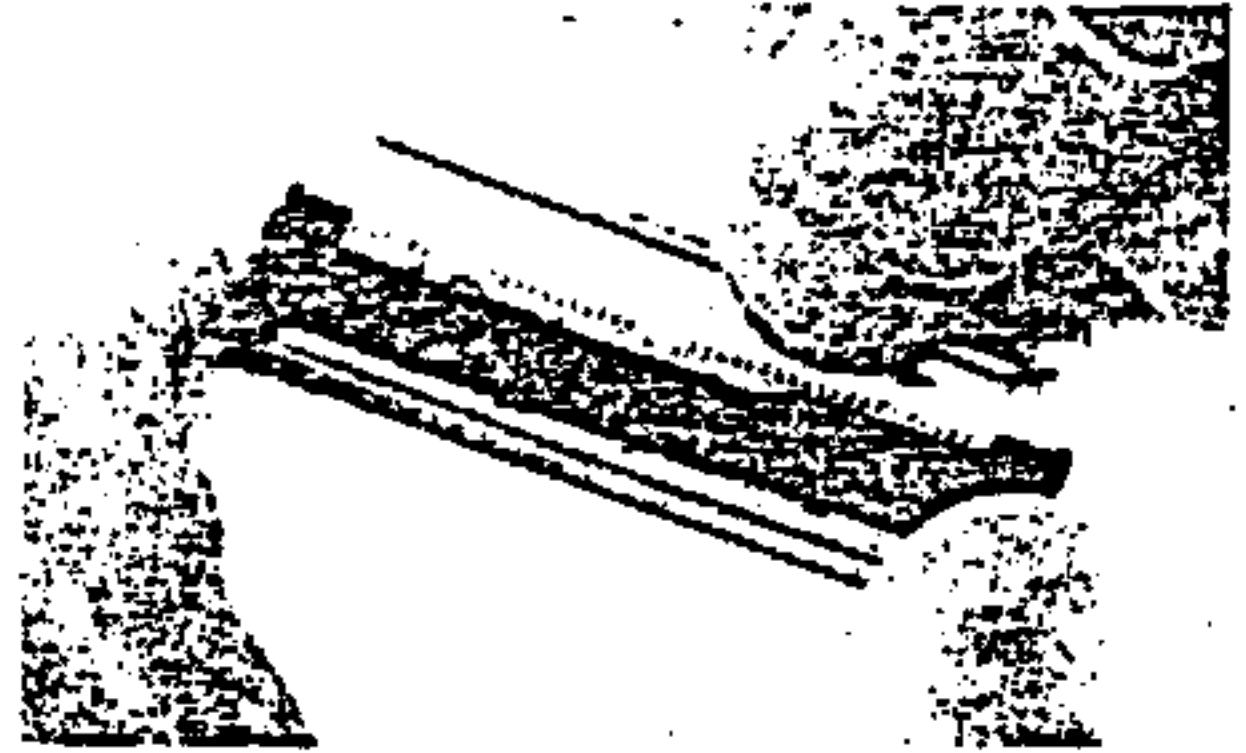

**4 LOGIC PCA REPLACEMENT**

After separating the case (procedure 1):

- a. Unscrew the two nuts holding the logic PCA. Use the 1/4-inch nut driver (8720-0002).
- b. Lift off the logic PCA.
- c. If necessary, replace the logic connector. Be sure it is retained by the posts on the keyboard assembly.

**CAUTION**

When removing the alarm disk, lift the foam tape with a thin tool. If you pull on the edge of the disk, the disk may be damaged.

- d. Check the alarm-disk position to ensure that it is properly located on the logic PCA. A piece of two-sided foam tape located on the power supply (U2) holds the alarm, which is centered across the width of the PCA and has its upper edge centered on inductor L1.
- e. Check that the battery cover is not damaged and is properly located by the upper posts on the keyboard assembly.
- f. Install the logic PCA over the posts on the keyboard assembly, making sure that the components face upward, away from the keyboard PCA. Make sure that all leads have been trimmed on the underside of the logic PCA.

**CAUTION**

Do not apply excessive torque when tightening the retaining nuts; excessive torque may deform the top case or damage the threads. If the threads are damaged, use undersized nuts, part number 2740-0013.

- g. Install the two nuts onto the posts using the 1/4-inch nut driver. Tighten them until the logic PCA is securely clamped in position.

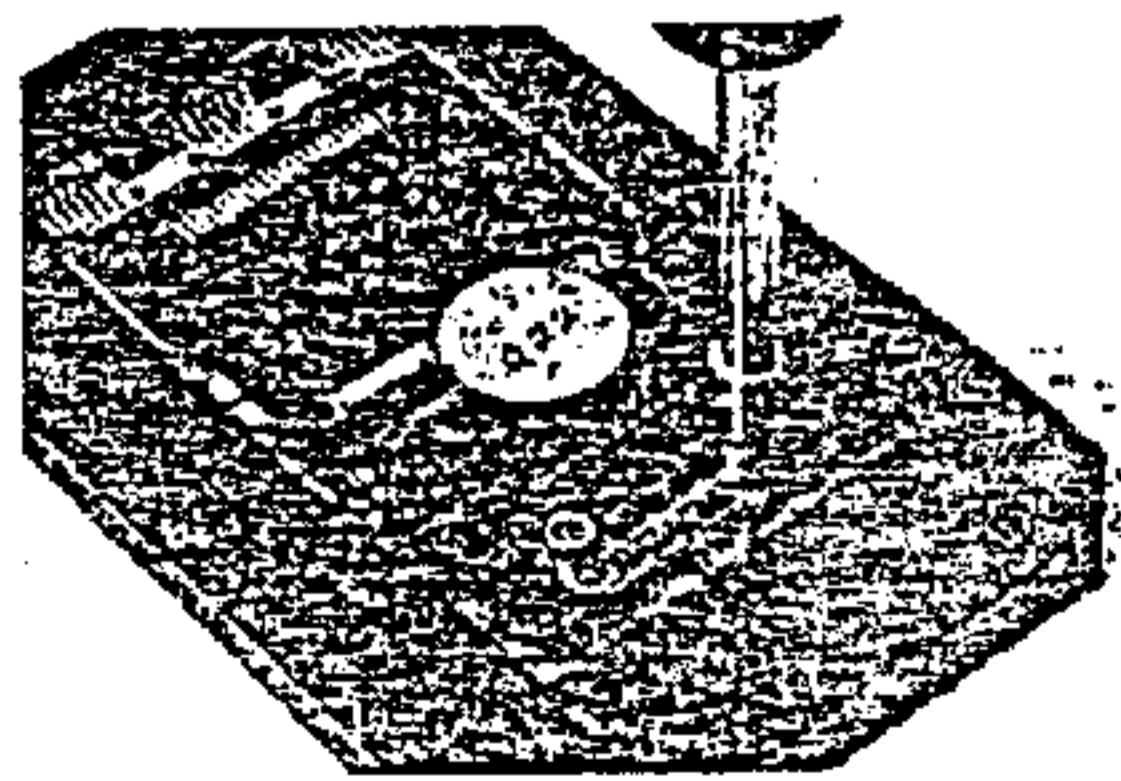
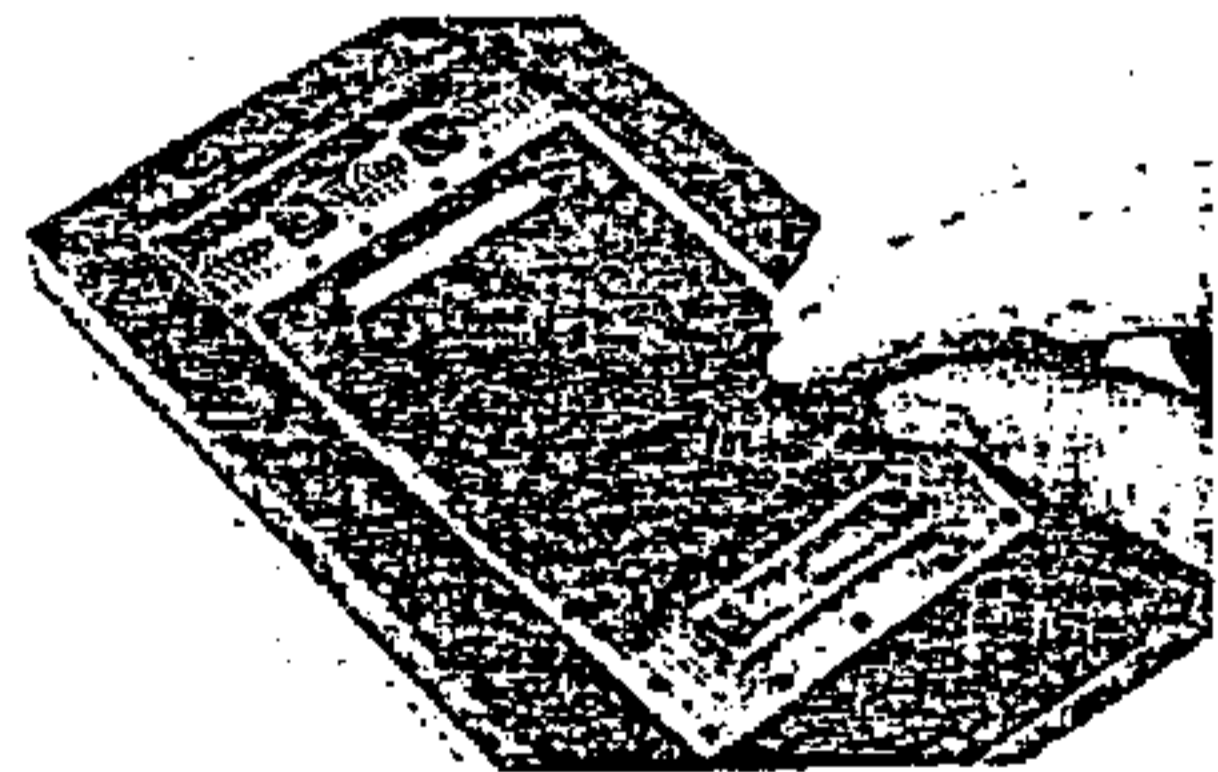
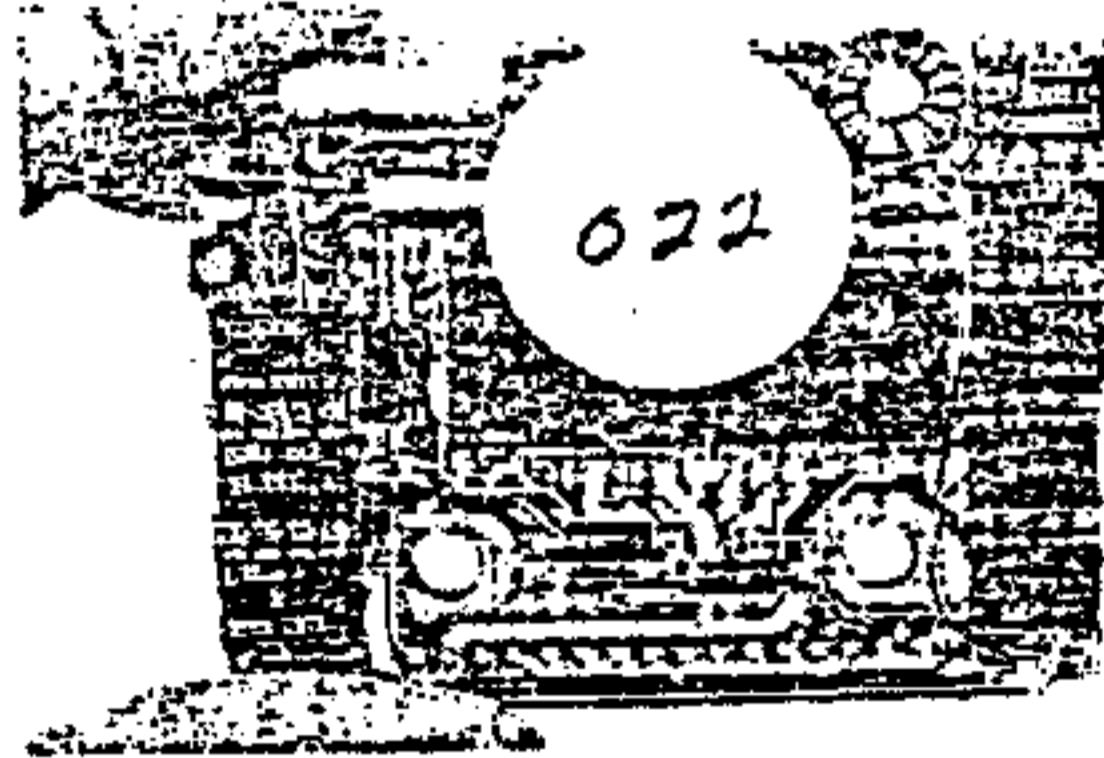
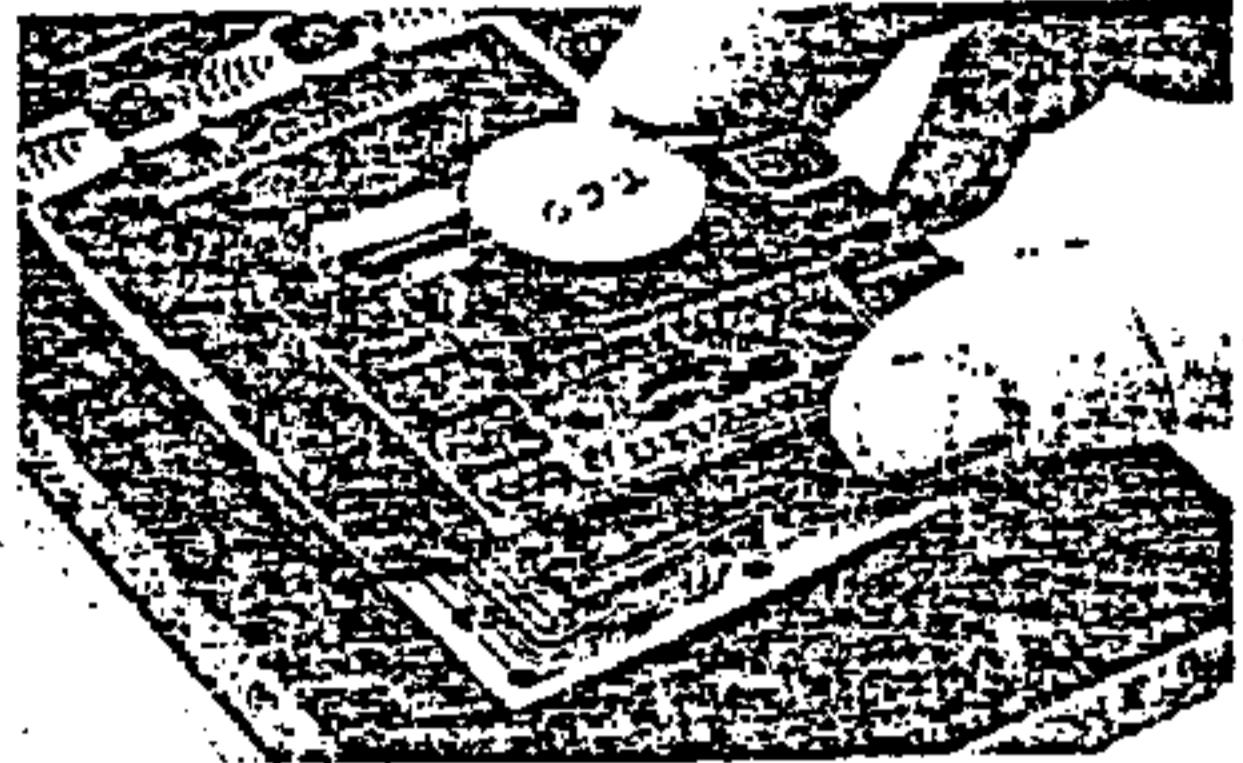

## 5

## CASE REASSEMBLY

- a. Position the center case on the keyboard assembly. The sides of the center case have a slight slant. Place the narrower span against the keyboard assembly.

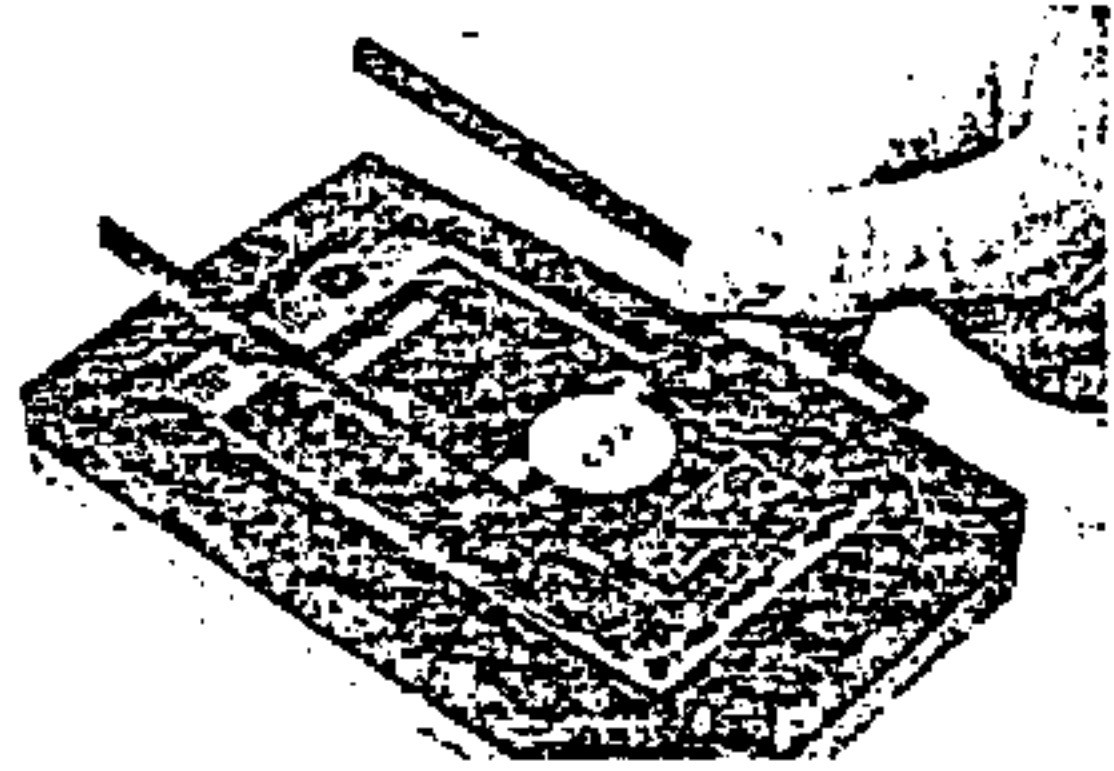

- b. Install the bottom case onto the center case. Make sure that the I/O contact assembly is seated squarely in the bottom case. The bottom case should not completely seat against the center case unless pressure is exerted to compress the I/O contact assembly and alarm spacer.



- c. Install the four screws through the foot recesses in the bottom case, installing the two longer screws at the upper end of the calculator. If the case threads at the lower end are damaged, use longer screws, part number 0624-0436.
- d. Attach four new rubber feet in the recesses on the bottom case, pressing firmly to assure complete bonding.
- e. Install batteries in the battery case. Observe the alternating orientation of the batteries as shown by the symbols on the closed end of the battery case.
- f. Insert the battery case by placing its open end into the bottom case adjacent to the contact assembly, and then pressing the battery case up and in.

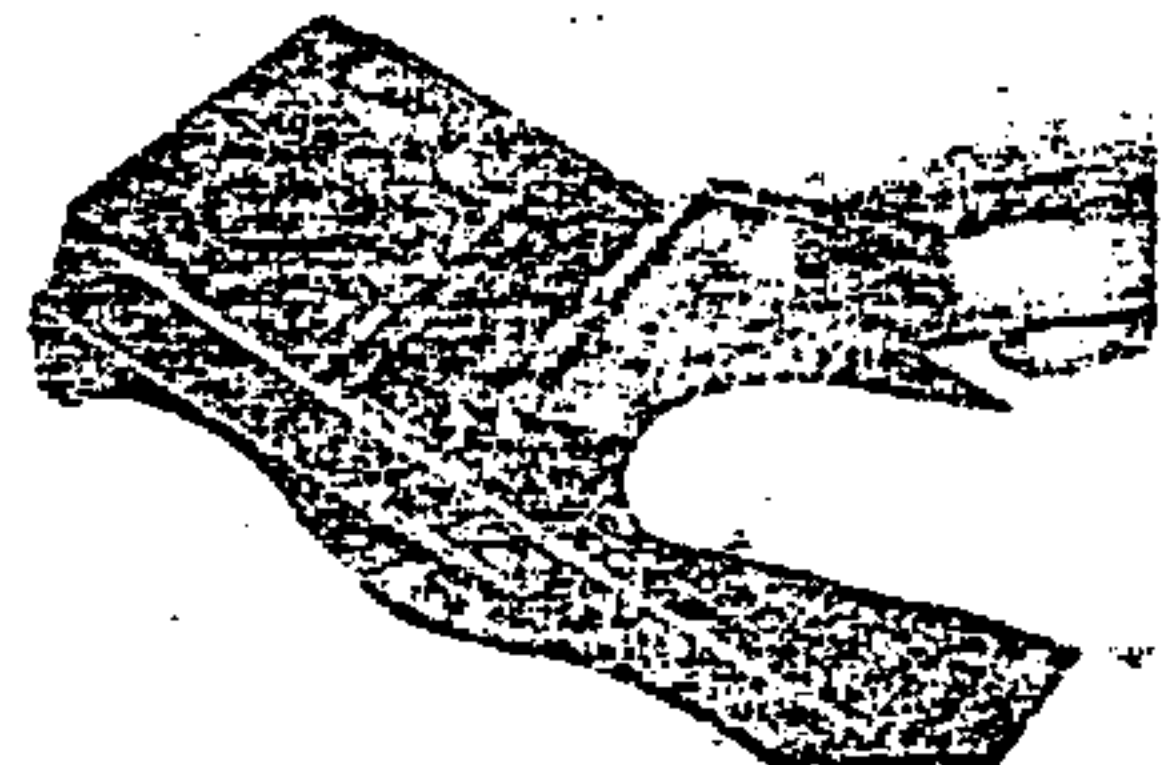
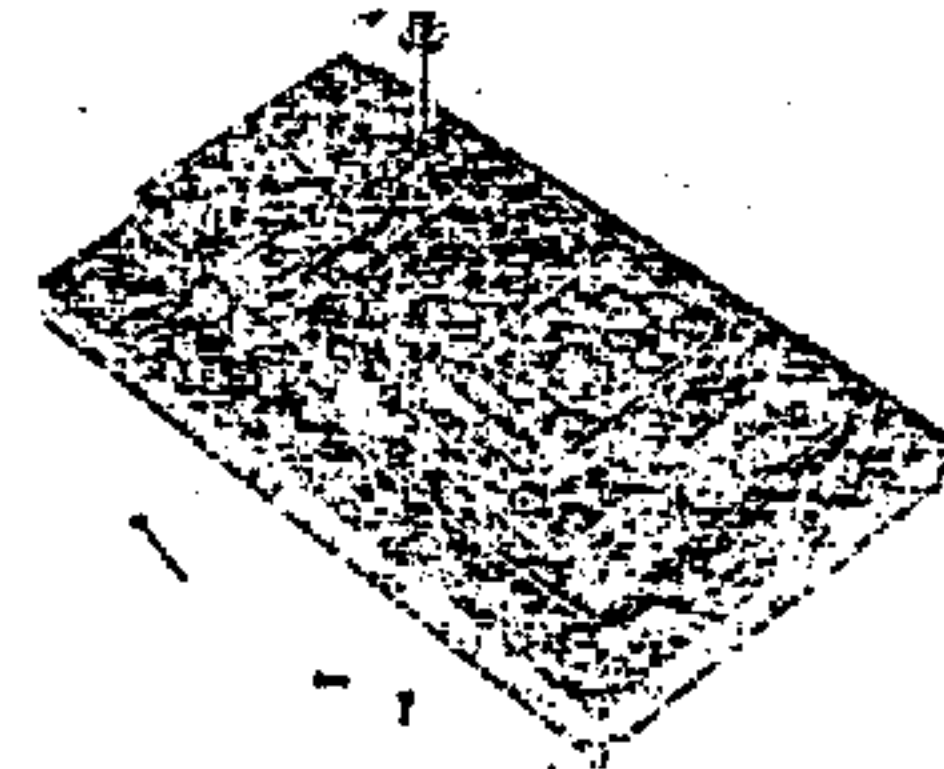

# Troubleshooting and Testing

## 4-1. INTRODUCTION

4-2. The troubleshooting and testing procedures presented in this manual deal with the HP-41C calculator only. Service information for plug-in accessories compatible with the HP-41C system is covered in a separate manual for each accessory.

4-3. The troubleshooting and testing procedures incorporate the use of a plug-in service module, which is capable of testing the entire calculator and indicating faulty components. The service module and other tools used to service the HP-41C are listed in table 4-1. Key reassignments made by the service module are shown in figure 4-1.

Table 4-1. Recommended Tools

HP PART/ MODEL NUMBER	DESCRIPTION
ET-11966	Service Module
ET-11967	Flag-Wired Memory Module
T-11945	Port Extender
T-155781	Service Clamp
	Test Calculator Parts:
T-190639	• Modified Keyboard Assembly
T-190638	• Modified Bottom Case
T-93328*	Molded Holding Nest
8720-0002	Nut Driver, 1/4-inch
HP 82106A	Memory Module (2 required)
8690-0227	Desoldering Tool, antistatic
8690-0253	Desoldering Tool Tip, antistatic
8690-0129	Soldering Iron
8690-0132	Soldering Iron Stand
8700-0003	X-acto Knife
8700-0006	X-acto Knife Blade
8730-0008	Small Flat-Blade Screwdriver
8730-0020	Phillips Screwdriver
HP 190C/1801A/1820C†	Oscilloscope. Measures pulse at 0.50μs; maximum amplitude 13 Vdc.
0960-0062	Continuity Tester
HP 6213C†	Power Supply. Variable supply rated at 10 Vdc at 5A. (Add a 0.1 μf ceramic capacitor across output terminals.)
HP 3469B†	Multimeter. Accurate to 0.01 Vdc.
HP 10004†	Oscilloscope Probe
8300-0398	Finger Cots
00041-90001	HP-41C Owner's Handbook and Programming Guide

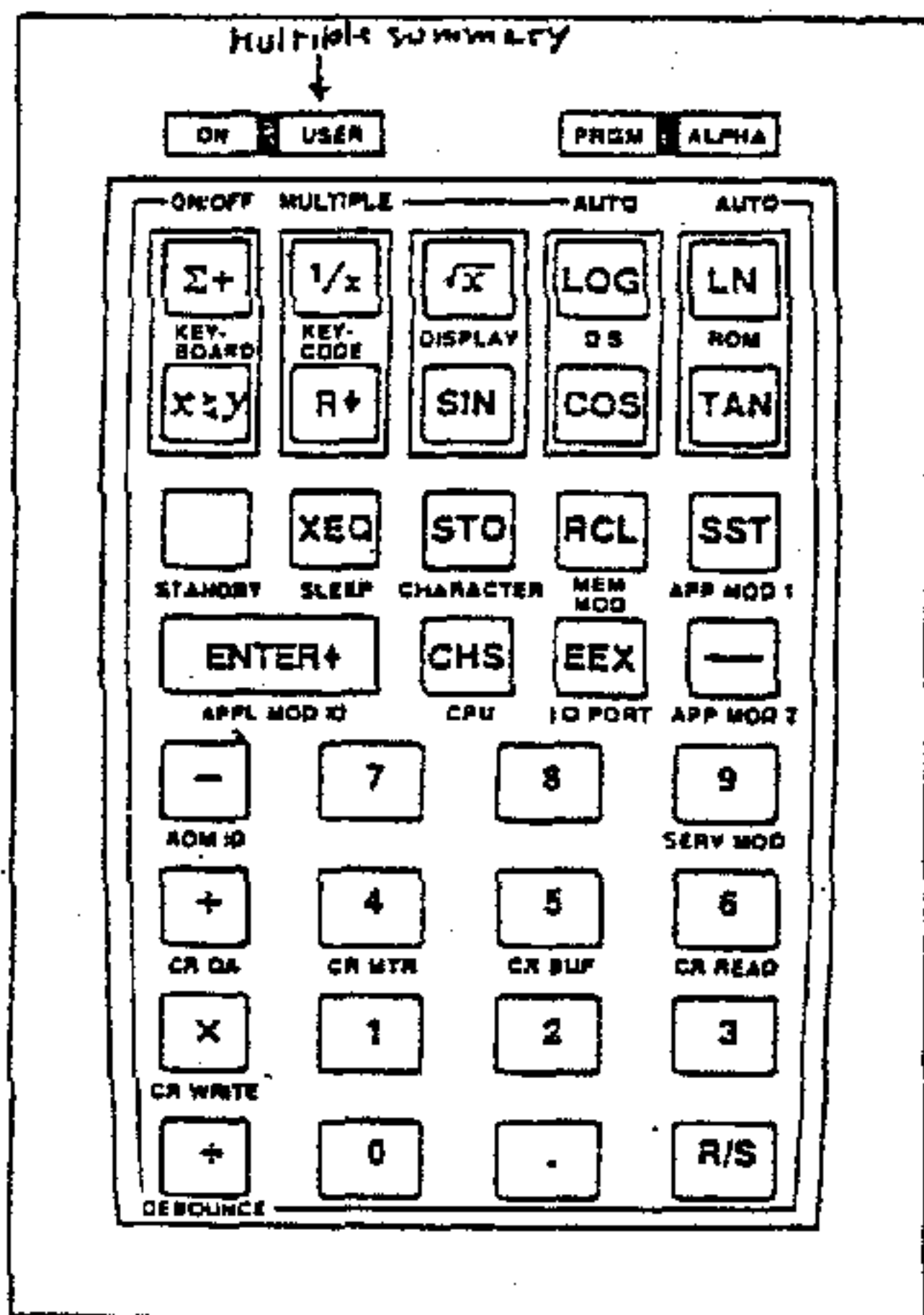

Figure 4-1. Key Assignments for Service Module

\* Same as that for Classic and Series E.

† Or equivalent.

4-4. The following paragraphs describe the procedures that are necessary to troubleshoot the HP-41C. The diagnostic test detailed in paragraph 4-7 is also used as the performance test to verify the proper operation of the calculator after it is repaired. Read through the entire procedure, including table 4-2, before attempting to troubleshoot a calculator.

**CAUTION**

Ensure that adequate precautions are taken regarding electrostatic protection. Use the antistatic desoldering tool (8690-0227) and work at a bench setup that is electrostatically protected. Otherwise, IC's may be damaged.

**4-5. INITIAL PREPARATION**

4-6. Perform the following steps before attempting to troubleshoot the calculator:

- a. Visually inspect the calculator for case damage (including the overlay latch), I/O contact damage, LCD cracks, discoloration, and bubbles (dark spots). Note any parts that require replacement.
- b. Install four good batteries in the calculator. Observe the alternating orientation of the batteries as shown by symbols on the closed end of the battery case.
- c. Determine the customer's concern, if possible. Frequently the customer includes with the calculator a message describing the problem.
  - If the problem relates to low-battery detection, first perform the diagnostic test sequence (paragraph 4-7) and then perform the low-level detection test (paragraph 4-13).

- If the problem relates to the calculator not turning on or not responding to keystrokes, reset the CPU by removing and reinstalling the battery pack. Then perform the diagnostic test sequence (paragraph 4-7). (If the customer has already removed the batteries, this will have reset the CPU).
- For other problems, or if the problem is not known, perform only the diagnostic test (paragraph 4-7).
- If the customer returns the batteries with the calculator, test them using the battery test (paragraph 4-16).

**4-7. DIAGNOSTIC TEST**

4-8. Perform the diagnostic test procedure outlined below. For each step that is described, the proper LCD display is shown at the right. This listing gives the responses for a good calculator; other responses can occur and indicate improper operation. (Each \* below denotes an alarm beep.)

- If the proper responses are observed, the calculator is good.
- If an error display occurs, refer to the corresponding section of the detailed listing (table 4-2) and continue testing using that table. Be sure to record each LCD error message to aid the repair process. Repair the calculator according to paragraph 4-9.

**Note:** Do not operate the calculator on batteries for an extended period of time with the service module plugged in. This module prevents the system from switching to a low-power mode and can cause excessive battery drain.

<p><b>1</b> Preparation</p> <p>Be sure the calculator is off.</p> <p>Insert service module in lower left I/O port.</p> <p>Insert flag-wired module in lower right I/O port.</p> <p>Insert two memory modules in upper I/O ports.</p>	<p>(blank display)</p> <p>(blank display)</p> <p>(blank display)</p> <p>(blank display)</p>
<p><b>2</b> CPU</p> <p>Press the <b>ON</b> key.</p>	<p>SELECT TEST ( ** )</p>



## 4-9. REPAIR AND TEST

4-10. After completing the procedures in the diagnostic test sequence, replace bad components using the guidelines below. For reference information concerning component locations and part numbers, use figures 4-6, 4-7, and 6-1 and tables 4-5 and 6-1.

- If any components are individually specified as bad, replace them.
- If any components are specified as possibly bad, decide which test errors may be related and replace the component that is most likely causing them.
- Certain error possibilities may be resolved by installing the logic PCA in a test calculator and trying the appropriate tests again.
- If the same ROM error occurs after any indicated ROM's have been replaced, other ROM's may be interfering with their operation. In this case, replace other ROM IC's until the ROM error is

corrected. Replace them in the order of ROM 0, ROM 2, ROM 1, omitting any that have already been replaced.

- If memory is not preserved in low-power modes (standby or sleep tests), replace the indicated IC's only if a few are specified or if they may be causing other error conditions. If most of the IC's included in the low-power memory check are specified, replace the power supply (bipolar) IC. (Refer to table 4-4 for additional power supply troubleshooting information.)

4-11. Rerun the entire diagnostic test (paragraph 4-7) after repairing the logic PCA or the calculator. The logic PCA may be tested using a test calculator as shown in figure 4-2. Test the complete calculator without fully assembling it by using the service clamp shown in figure 4-3. If additional repairs are required, be sure to rerun the diagnostic test.

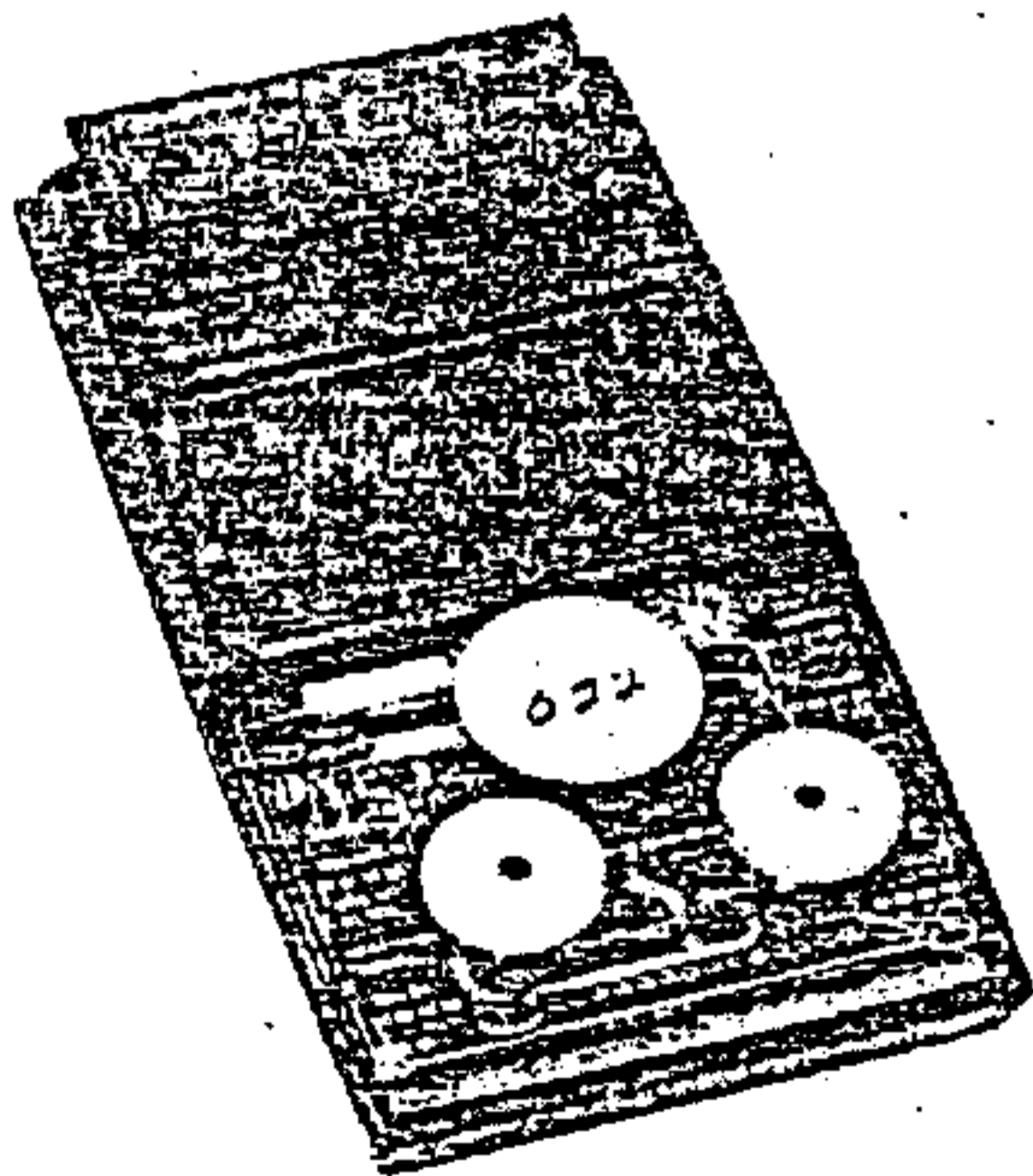

Figure 4-2. Test Calculator

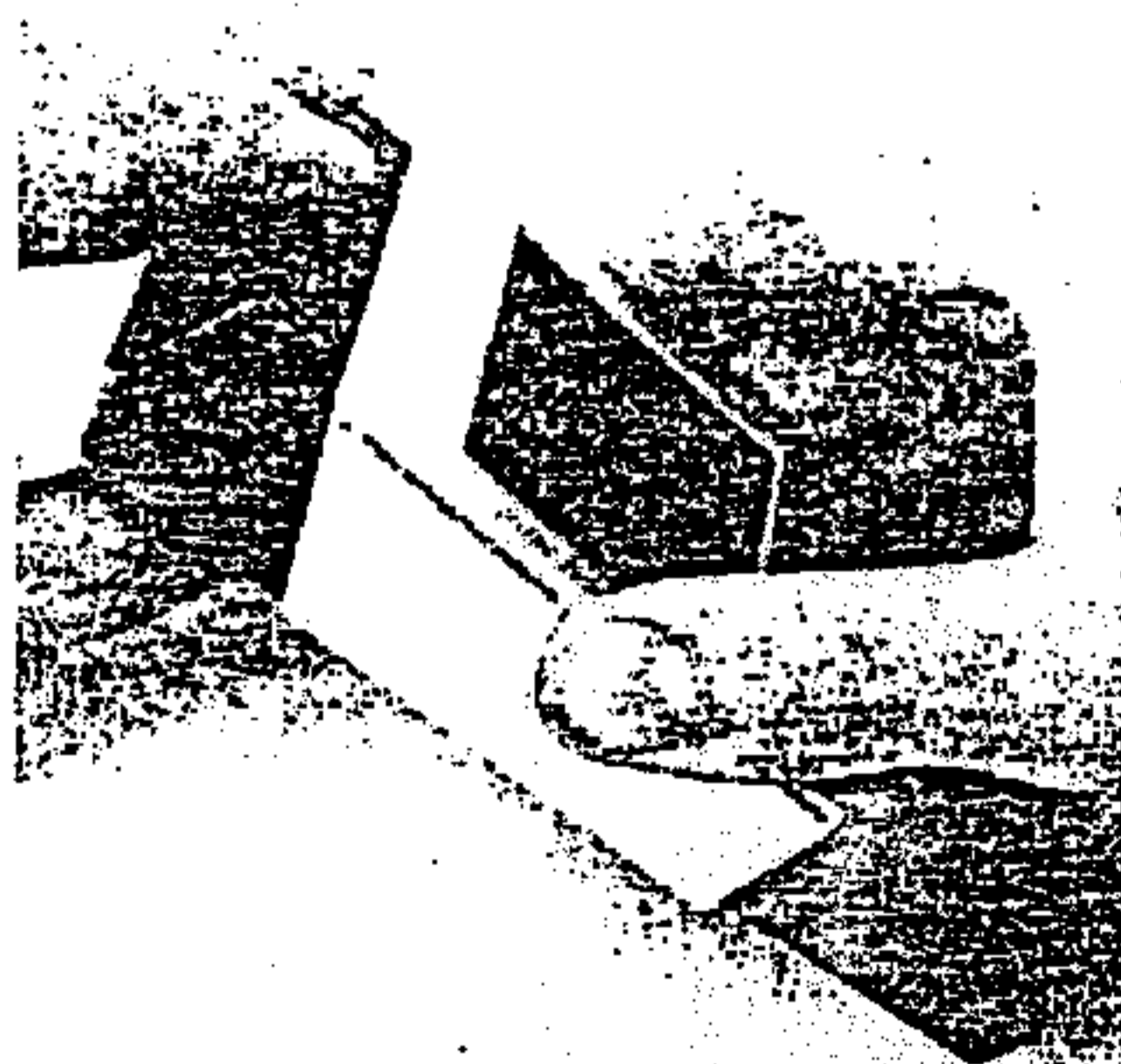

Figure 4-3. Service Clamp



Table 4-2. Detailed Diagnostic Test Procedure

This table presents a detailed description of the diagnostic test procedure. For each step, conditions that can occur are listed and the LCD displays are shown.	
STEP	DISPLAY
<p><b>1</b> Preparation</p> <p>a. Be sure that the calculator is off. If the display is active, press the <b>ON</b> key to turn it off.</p> <p>b. Insert the service module in the lower left I/O port. Do not insert any modules while the calculator is turned on.</p> <p>c. Insert a flag-wired memory module in the lower right I/O port. This module permits the testing of the FI (flag in) line from the I/O port.</p> <p>d. Insert two good memory modules in the remaining I/O ports. These modules provide additional loading on the system lines in order to approximate worst-case operating conditions and permit testing of all I/O ports.</p>	
<p><b>2</b> CPU Test</p> <p>a. Press the <b>ON</b> key to turn on the calculator and start the diagnostic test. Watch for:</p> <ul style="list-style-type: none"> <li>• Triple beeps and this flashing LCD message indicate that the alarm and tested portion of the CPU are good. If this expected display is not observed, but portions of it are recognizable in the actual display, or if the display is flashing, then the CPU is still considered to be good. (The message CPU OK may appear momentarily in the display.)</li> <li>• This LCD message indicates that the CPU is bad. Press the <b>ON</b> key to turn off the calculator. Refer to table 4-3.</li> <li>• For any other CPU test result, the diagnosis or procedure is given in table 4-3.</li> </ul> <p><b>Note:</b> An erratic, intermittent, or squealing sound is not a valid alarm beep. If such a sound persists, it indicates that the CPU is not properly controlling the alarm signal.</p> <p>b. If the alarm is bad, replace it now only if the CPU is being replaced or if the expected display was not recognizable, then restart the diagnostic test. Otherwise, replace a defective alarm when replacing other components or at the end of the test.</p> <p>c. Press the <b>USER</b> key to select the multiple test sequence with manual interaction, consisting of tests 3 through 9.</p>	<p><b>SELECT TEST</b></p> <p><b>CPU BAD</b></p>

Table 4-2. Detailed Diagnostic Test Procedure (Continued)

STEP	DISPLAY
<p><b>3</b> <b>Display Test</b></p> <p>a. Watch for:</p> <ul style="list-style-type: none"> <li>• This LCD message or a continuous alarm tone indicates that there is a bad D/S IC in the system. If the plug-in memory modules are known to be good and the LCD message is legible, press the <b>[R/S]</b> key to go on to the next test. Otherwise, perform step c.</li> <li>• This LCD message or a series of single beeps indicates that the display driver or CPU is bad. If the LCD message is legible, press <b>[R/S]</b> key to go on to the next test. Otherwise, perform step c.</li> <li>• This LCD message or a series of double beeps indicates that the display driver is bad. If the LCD message is legible, press the <b>[R/S]</b> key to go on to the next test. Otherwise, perform step c.</li> </ul> <p>b. Observe the three visual tests to evaluate the brightness, contrast, and response of the LCD unit. Make sure that there are no missing or extra segments. Press and hold the <b>[R/S]</b> key to make the display pause; release it to continue.</p> <p>(1) <i>Starburst-comma-annunciator test.</i> Check that all LCD segments (except upper dots) turn on. Look for both segments in each comma.</p> <p>(2) <i>S-colon test.</i></p> <p>(3) <i>@-test.</i></p> <p>c. Replace faulty components indicated by previous LCD messages or by the visual test, and then restart the diagnostic test. Evaluate components as follows:</p> <ul style="list-style-type: none"> <li>• Nonuniform or weak contrast or black spots (bubbles) in the display indicate that the LCD is bad. A bad power supply (bipolar) IC or improper operation of the clock in the display driver can also cause poor overall contrast.</li> <li>• Improper operation of display segments or no display is most likely caused by a bad display driver. Other less likely causes include defective display connectors, a bad LCD, and a bad power supply (bipolar) IC.</li> </ul>	<p><b>SOME DIS BAD</b></p> <p><b>DRIV/CPU BAD</b></p> <p><b>DISP DRV BAD</b></p> 
<p><b>4</b> <b>D/S Test</b></p> <p>Watch for:</p> <ul style="list-style-type: none"> <li>• Any change in the display indicates that the display driver is bad.</li> <li>• This LCD message indicates that all internal D/S IC's are good.</li> <li>• This LCD message indicates that any specified D/S IC's are bad. Press the <b>[R/S]</b> key to continue.</li> </ul>	<p><b>D/S TEST</b></p> <p><b>D/S OK</b></p> <p><b>D/S 0, 2, BAD</b></p>

Table 4-2. Detailed Diagnostic Test Procedure (Continued)

STEP	DISPLAY
<p><b>5</b> ROM Test</p> <p>a. The flag annunciators indicate which ROM IC is being tested (0, 1, or 2).</p> <p>b. Watch for:</p> <ul style="list-style-type: none"> <li>• This LCD message indicates that all internal ROM's are good.</li> <li>• This LCD message indicates that any specified ROM IC's are bad. Press the <b>[R/S]</b> key to continue.</li> </ul>	<p>ROM TEST</p> <p>ROM OK</p> <p>ROM 0,2,BAD</p>
<p><b>6</b> Keyboard Test</p> <p>a. Press each keyboard key, left-to-right, top-to-bottom. This includes the four operating (switch-type) keys at the upper end of the keyboard. Watch for:</p> <ul style="list-style-type: none"> <li>• A beep or this LCD message after each keystroke indicates that each pressed key is good. Continue pressing keys.</li> <li>• This LCD message after all of the keys have been pressed indicates that all of the keys are good. Go on to step b.</li> <li>• This LCD message indicates that a double entry has been caused by noisy key contact. Press the <b>[R/S]</b> (or <b>[ON]</b>) key twice to go on to step b.</li> <li>• This LCD message indicates that the pressed key is bad or that the keying was improper. Press the <b>[R/S]</b> (or <b>[ON]</b>) key twice to go on to step b.</li> </ul> <p>b. Decide whether to test the keyboard again. This decision also will influence the keycode test later.</p> <ul style="list-style-type: none"> <li>• If all of the keys are good, press the <b>[R/S]</b> key or <b>[N]</b> (no) key to go on to the next test.</li> <li>• If a keyboard error occurred, press the <b>[Y]</b> (yes) key or the <b>[E←]</b> or <b>[XLY]</b> key (keyboard test keys) to repeat this test. Note which keys cause errors or whether improper keying causes errors.</li> </ul>	<p>KYBOARD TEST</p> <p>KYBOARD TEST</p> <p>KYBOARD OK</p> <p>DOUBLE ENTER</p> <p>KYBOARD BAD</p> <p>KYBD AGAIN?</p>
<p><b>7</b> Standby Test</p> <p>a. Observe the display for at least 3 seconds after the start of this test:</p> <ul style="list-style-type: none"> <li>• No changes in the composition and quality of the display indicate that the display driver is good.</li> <li>• Any change in the display indicates that the display driver, oscillator capacitor (C2), or CPU is bad.</li> <li>• This LCD message indicates that the CPU is bad. Press the <b>[R/S]</b> key to go on to the next test.</li> </ul> <p>b. Press any key (except <b>[ON]</b>) after the observation period, but before 10 minutes has elapsed. Watch for:</p> <ul style="list-style-type: none"> <li>• This LCD message indicates that the calculator operates properly in STANDBY power mode.</li> <li>• This LCD message indicates that the contents of any indicated components are not preserved in STANDBY mode. This test checks the contents of the D/S IC's (0 through 4). Either the indicated IC's or the power supply (bipolar) IC is bad. Press the <b>[R/S]</b> key to continue.</li> </ul>	<p>STANDBY TEST</p> <p>CPU BAD</p> <p>STANDBY OK</p> <p>MEM 1,2,LOST</p>

Table 4-2. Detailed Diagnostic Test Procedure (Continued)

STEP	DISPLAY
<p><b>8</b> Sleep Test</p> <p>a. Observe the display after the start of this test:</p> <ul style="list-style-type: none"> <li>• A blanked display indicates that the display has been properly disabled.</li> <li>• This LCD message indicates that the CPU is bad. Press the <b>[R/S]</b> key to go on to the next test.</li> <li>• Any other display indicates that the display driver is probably bad. A bad CPU is a second, but less likely, cause.</li> </ul> <p>b. Press the <b>[R/S]</b> key to check for no response. Any other keys (except the <b>[ON]</b> key) may also be tried. Watch for:</p> <ul style="list-style-type: none"> <li>• No response is the proper outcome.</li> <li>• Any response indicates that the display driver or CPU is bad. Also, the next step may not function properly.</li> </ul> <p>c. Press the <b>[ON]</b> key to turn on the calculator. Watch for:</p> <ul style="list-style-type: none"> <li>• A beep and this LCD message indicates that the calculator operates properly in SLEEP power mode.</li> <li>• This LCD message indicates that the contents of any indicated components are not preserved in SLEEP mode. This test checks the contents of the display driver (D) and D/S (0 through 4). Either the indicated IC's or the power supply (bipolar) IC is bad. Press the <b>[R/S]</b> key to continue.</li> </ul>	<p><b>SLEEP TEST</b></p> <p>(blank display) <b>CPU BAD</b></p> <p><b>SLEEP OK</b></p> <p><b>MEM D,2,LOST</b></p>
<p><b>9</b> Summary</p> <p>a. Watch for:</p> <ul style="list-style-type: none"> <li>• This LCD message indicates that the tested portions of the electronic components are good. This message does <i>not</i> give any indication of alarm or LCD performance.</li> <li>• This LCD message is a reminder that the indicated tests in this sequence were not passed. These tests are summarized: display (1), D/S (2), ROM (3), keyboard (4), standby (5), and sleep (6).</li> </ul> <p>b. Press the <b>[R/S]</b> key to select the next test.</p>	<p><b>ALL TESTS OK</b></p> <p><b>ERROR 3,6,</b></p> <p><b>SELECT TEST</b></p>
<p><b>10</b> Character Test</p> <p>a. Press the <b>[STD]</b> key to select the character test.</p> <p>b. Observe the seven LCD displays for improper character structure (extra or missing segments). Any improper structure indicates that the display driver is bad. Press and hold the <b>[R/S]</b> key to make the display pause; release it to continue.</p> <p>c. Press the <b>[R/S]</b> key to select the next test.</p>	<pre> Q ABCDEFGHIJK L MNOPQRSTUW X YZ[ ]^_`{ }~ 5 6 7 8 9 0 1 2 3 4 5 6 7 8 9 0 0 1 2 3 4 5 6 7 8 9 0 1 2 3 4 5 6 7 8 9 0 1 2 3 4 5 6 7 8 9 0 1 2 3 4 5 6 7 8 9 0 1 2 3 4 5 6 7 8 9 0 1 2 3 4 5 6 7 8 9 0                 </pre> <p><b>SELECT TEST</b></p>

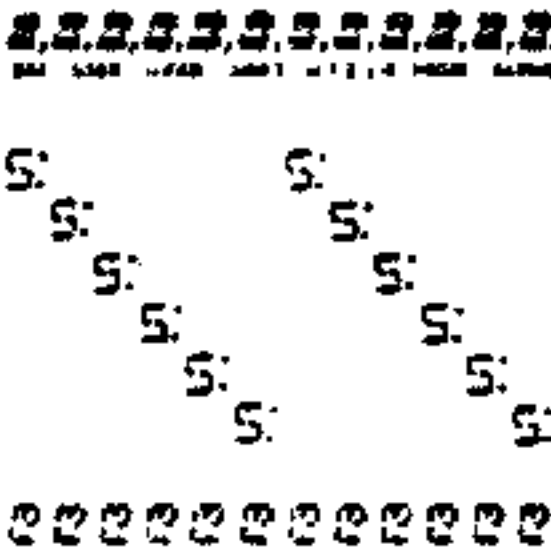
Table 4-2. Detailed Diagnostic Test Procedure (Continued)

STEP	DISPLAY
<p><b>11</b> <b>Keycode Test</b></p> <p>a. Press the <b>[F7]</b> or <b>[F8]</b> key to select the keycode test.</p> <p>b. If the keyboard is good as determined from the earlier keyboard test, go to step c.</p> <p>c. Press each suspected key as determined from the keyboard test. Note which keys give erroneous responses. Watch for:</p> <ul style="list-style-type: none"> <li>• If the proper keycode is displayed, that key is functioning properly. The keycode represents the row and number of the pressed key. (The upper four operating keys comprise row 0.)</li> <li>• If there is no response, use step d to determine the bad component.</li> <li>• If the wrong keycode is displayed, use step d to determine the bad component.</li> <li>• This LCD message indicates that a double entry has been caused by noisy key contact. (Rapid double-keying can also cause this message.)</li> <li>• This LCD message indicates that the CPU is bad.</li> </ul> <p>d. Press other keys on the same row and column line as each bad key (see below) to determine if it is an isolated bad key or a bad row or column:</p> <ul style="list-style-type: none"> <li>• If there is an isolated bad key, the keyboard assembly is bad. (Exception: an isolated key giving an incorrect keycode indicates a bad CPU.)</li> <li>• If there is a bad row or column, a key line is open or shorted (keyboard assembly, logic board, logic connector) or the CPU is bad.</li> </ul>	<p><b>KEYCODE TEST</b></p> <p><b>43</b></p> <p><b>DOUBLE ENTER</b></p> <p><b>CPU BAD</b></p>
 <p><b>ROW LINES</b></p>	 <p><b>COLUMN LINES</b></p>

Table 4-2. Detailed Diagnostic Test Procedure (Continued)

STEP	DISPLAY
<p>e. Press keys in the rollover area (2, 4, 5, 6, and 8 keys) to test for proper two-way rollover response. For each of the four combinations, press and hold the 5 key, press and hold one of the adjacent keys, release the 5 key (observing the corresponding keycode, 63, in the display), and then release the second key (observing its row and key number). A keycode should appear in the display when the key is released.</p> <ul style="list-style-type: none"> <li>• If both keycodes are correct for each combination, the CPU is properly detecting the keys.</li> <li>• If either keycode is not correctly displayed for any combination and all of the keys operated properly individually, then the CPU is bad.</li> </ul> <p>f. Press the <b>R/S</b> (or <b>ON</b>) key twice to go on to the next test.</p>	<p style="text-align: center;"><b>SELECT TEST</b></p>
<p><b>12</b> <b>I/O Port Test</b></p> <p>a. Press the <b>EEZ</b> key to select the I/O port test. Be sure that the service module and a flag-wired memory module are inserted in the lower I/O ports and that two good memory modules are inserted in the upper I/O ports. With this set-up, this test checks all I/O port lines <i>except</i> V<sub>BAT</sub> at all ports, DATA at the service module port, and FI at the two ports to the side of the flag-wired module port. Watch for:</p> <ul style="list-style-type: none"> <li>• This LCD message indicates that the tested port lines are good.</li> <li>• This LCD message indicates that any specified function or port does not respond properly. This test checks the FI line (F) and all four ports: upper left (1), upper right (2), lower left (3), and lower right (4). The most probable cause is a bad I/O contact assembly.</li> </ul> <p><b>Note:</b> It is normal for the service module port to be included in this message since it does not respond on the DATA line. This is <i>not</i> an error condition.</p> <p>b. Press the <b>ON</b> key to turn off the calculator.</p> <p>c. Interchange the service and flag-wired modules in the lower I/O ports.</p> <p>d. Press the <b>ON</b> key to turn on the calculator.</p> <p>e. Press the <b>EEZ</b> key to select the I/O port test, proceeding as indicated in step a. (This retest checks the untested DATA and FI lines.)</p> <p>f. Press the <b>R/S</b> key to select the next test.</p>	<p style="text-align: center;"><b>IO PORT TEST</b></p> <p style="text-align: center;"><b>PORTS OK F,2,3,FAIL</b></p> <p style="text-align: center;"><b>SELECT TEST</b></p> <p style="text-align: center;"><b>SELECT TEST</b></p>
<p><b>13</b> <b>ROM Identification Check</b></p> <p>a. Press the <b>□</b> key to select the internal ROM identification check. This LCD message indicates the revision code for each of the three internal ROM IC's.</p> <p>b. Press the <b>R/S</b> key to select the next test.</p>	<p style="text-align: center;"><b>ROM 0:D 1:D 2:C</b></p> <p style="text-align: center;"><b>SELECT TEST</b></p>
<p><b>14</b> <b>Test Selection/Completion</b></p> <p>a. If necessary, press any designated key to perform the corresponding test (see Figure 4-1) in order to verify a bad component. Normally, this step is not required.</p> <p>b. Press the <b>ON</b> key to turn off the calculator, completing the test.</p> <p>c. Remove the plug-in modules. Do not unplug them while the calculator is turned on.</p>	

Table 4-3. CPU Test Procedures

Use this table to interpret the results of the CPU test (performed by the service module). For a particular outcome (column *a*), proceed as indicated in the column that corresponds to the present status of the calculator. Use columns *a* and *b* for the initial test of the calculator. If the logic PCA has already been tested and repaired, use columns *a* and *d*.

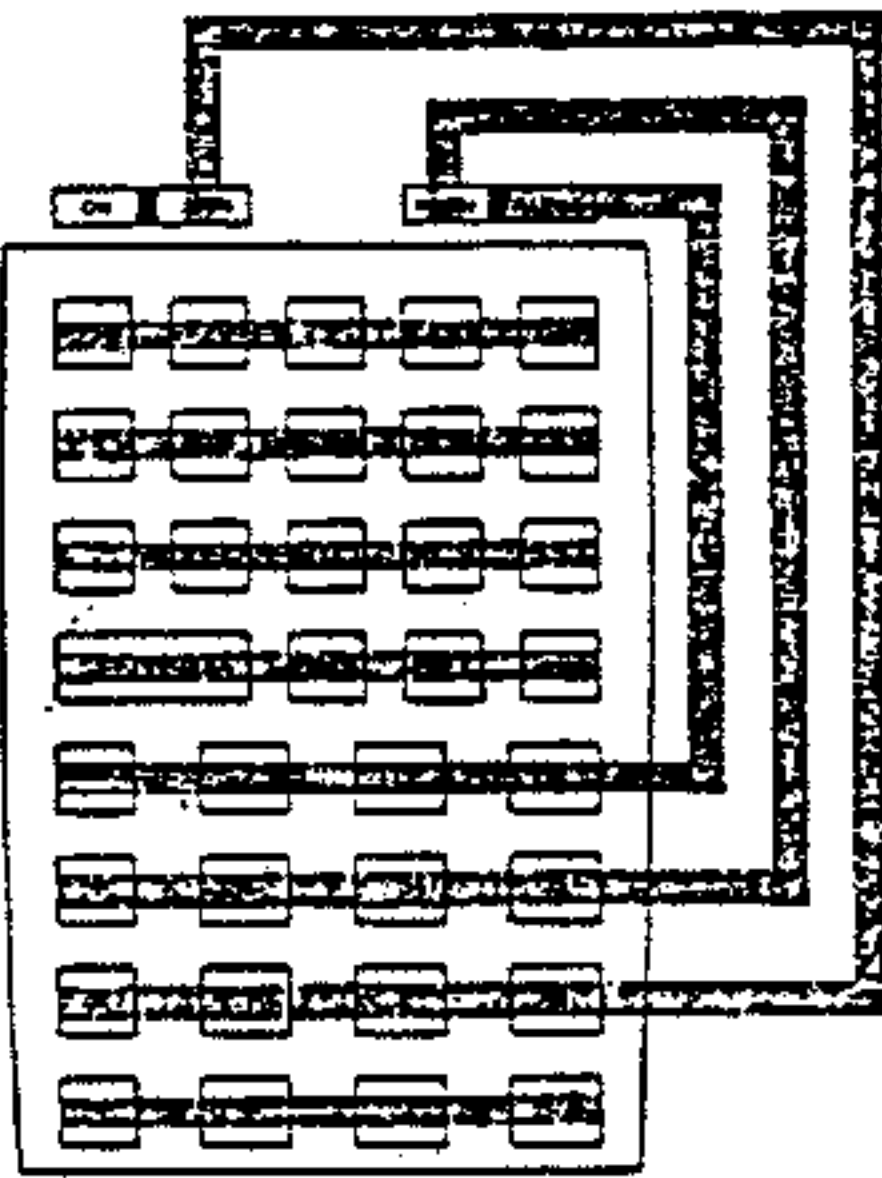
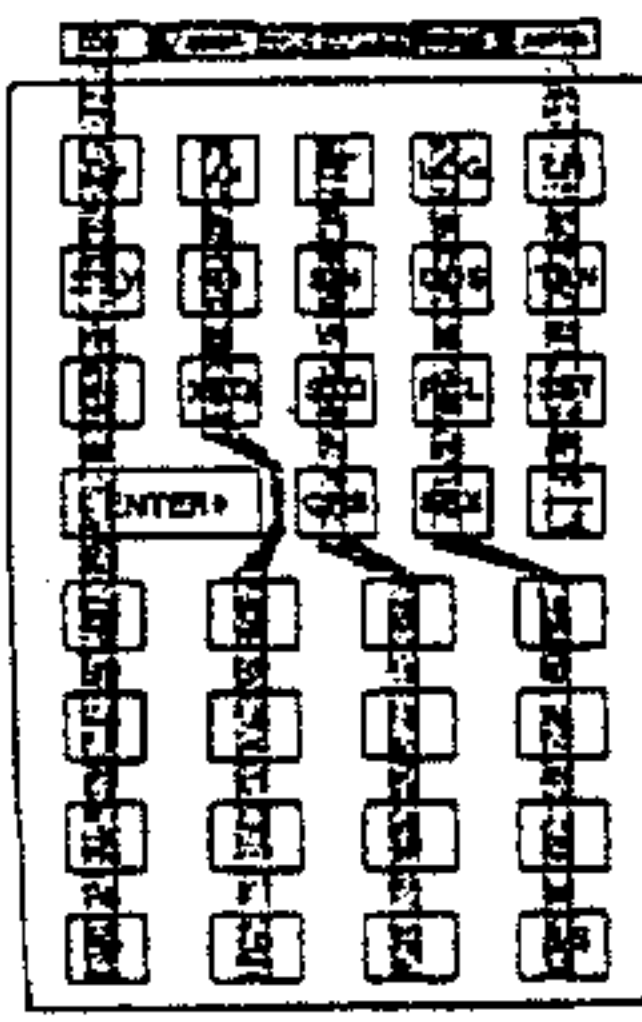
CPU TEST RESULTS (a)	DIAGNOSIS/PROCEDURE		
	Calculator with Untested Assemblies (b)	Logic PCA in Test Calculator (c)	Calculator with Good Logic PCA (d)
Triple beeps; <b>SELECT TEST</b> or flashing display	CPU good, alarm good. Proceed with diagnostic test.	CPU good, alarm good. Proceed with diagnostic test of logic PCA.	Proceed with diagnostic test.
Triple beeps; unrecognizable or blank display	CPU good, alarm good. Proceed with diagnostic test.	CPU good, alarm good. Proceed with diagnostic test of logic PCA.	Proceed with diagnostic test.
No beeps; <b>SELECT TEST</b> or flashing display	CPU good, alarm circuit bad. Proceed with diagnostic test.	CPU good, alarm circuit bad. Proceed with diagnostic test of logic PCA.	
No beeps; <b>CPU BAD</b> or other display	CPU bad, alarm circuit bad. Replace CPU and repair alarm circuit, then restart test.	CPU bad, alarm circuit bad. Replace CPU and repair alarm circuit, then restart test.	
Single beep; blank, <b>CPU BAD</b> , or other display	CPU bad, alarm good. Replace CPU and restart test.	CPU bad, alarm good. Replace CPU and restart test.	
No beeps; blank display	<ol style="list-style-type: none"> <li>1. Remove and insert battery pack, then restart test.</li> <li>2. Unplug any accessories and restart test.</li> <li>3. Test the logic PCA in test calculator. (Use columns <i>a</i> and <i>c</i> of this table.)</li> </ol>	<ol style="list-style-type: none"> <li>1. Check for power supply problems (table 4-4).</li> <li>2. Inspect traces and connector for defects, then restart test.</li> <li>3. Replace CPU and restart test.</li> </ol>	<ol style="list-style-type: none"> <li>1. Inspect traces and connectors for defects, then restart test.</li> <li>2. Replace display driver and restart test.</li> </ol>

**Note:** For a blank display, turn off the calculator by removing the battery pack.

Table 4-4. Power Supply Troubleshooting Procedure

<p>Use this procedure to check for power supply problems if the calculator will not turn on. After inspecting the traces for shorts, the logic PCA should be installed in a test calculator. Replace components as indicated in the second column. Proceed to the next step only if none of the conditions in the second column occur. Stop testing when the calculator can turn on.</p>	
STEP	ACTION
<ol style="list-style-type: none"> <li>1. Insert service module and port extender in I/O ports.</li> <li>2. Try to turn on the calculator.</li> <li>3. Measure <math>V_{CC}</math> (port extender).</li> <li>4. Measure <math>V_{IN}</math> of four good batteries in battery case.*</li> <li>5. Measure <math>V_{BAT}</math> (port extender).</li> <li>6. Measure <math>V_{CC}</math> (port extender).</li> <li>7. Press <b>ON</b> to turn on calculator.</li> <li>8. Measure <math>V_{CC}</math> (port extender).</li> <li>9. Measure <math>V_{C5}</math> (C5 lead next to C3).</li> <li>10. Observe CPU oscillator signal (across L1).</li> <li>11. Observe <math>\Phi 1</math>, <math>\Phi 2</math>, SYNC, and ISA signals (port extender).</li> </ol>	<p>If greater than 6.8V, replace U2.                      If 6.0 V to 6.8V, go to step 9.                      If less than 3.8V, check batteries, installation, battery case.                      If zero, check CR5, connectors, traces.                      If less than <math>(V_{IN}-0.5)</math> Vdc, check C1, C3, C9, C10, excessive IC load.                      If less than <math>(V_{BAT}-1.0)</math> Vdc, check CR2, T1, C3, C9, excessive IC load.                      If greater than 6.0V, go back to step 3.</p> <p>If greater than 6.8V, replace U2.                      If less than 6.0V, measure <math>V_{C1}</math> (R1 lead next to U7):</p> <ul style="list-style-type: none"> <li>• If <math>V_{C1}</math> is less than <math>(V_{CC}-1.5)</math> Vdc, replace U1.</li> <li>• If <math>V_{C1}</math> is greater than <math>(V_{CC}-1.5)</math> Vdc, check CR2, C3, C6, R2, R3, T1, replace U2 if necessary.</li> </ul> <p>If greater than 1V, check C5, replace U2, U1 if necessary.                      If no oscillations are observed, check C4, C7, L1, replace U1 if necessary.                      If all signals present and calculator does not respond, check connector (P1), replace U1, U3, U4, U5 if necessary.                      If some signals are present, remove and reinstall the battery case, then repeat this step. If some signals present, replace U1, check for excessive IC load.                      If no signals are present, replace U1.</p>
<p>* Measure <math>V_{IN}</math> either by removing the battery case from the calculator and electrically connecting the center batteries or by using the CR5 lead next to CR4 on the logic PCA.</p>	



**4-12. AUXILIARY TESTS**

**4-13. Low-Level Detection Test**

4-14. If necessary, perform the following steps to test the operation of the low-level detection circuit:

- a. Make sure the calculator is off.
- b. Remove the battery case from the calculator and set it aside.
- c. Insert the service module into the lower left I/O port.
- d. Insert the port extender into the lower right I/O port.
- e. Connect a variable dc power supply and dc voltmeter to  $V_{BAT}$  and GND on the port extender.
- f. Adjust the power supply to +5 to +6 Vdc at  $V_{BAT}$ .
- g. Press the **[ON]** key to turn on the calculator.
- h. Measure  $V_{CC}$  to be sure that it is 6.0 to 6.5 Vdc. If it is not, perform the power supply troubleshooting procedure (table 4-4).
- i. Vary  $V_{BAT}$  from 5.5 to 4.5 Vdc while repeatedly pressing the **[R/S]** key. (It is assumed that the

proper operation of the display assembly has been verified by the diagnostic test, paragraph 4-7.)

- If the BAT annunciator turns on and off at 4.5 to 5.0 Vdc at  $V_{BAT}$ , the low-level detection circuit is good.
  - Otherwise, the power supply (bipolar) IC or CPU is bad.
- j. Press the **[ON]** key to turn off the calculator.

4-15. Rerun the diagnostic test (paragraph 4-7) after making any repairs.

**4-16. Battery Test**

4-17. If it is necessary to test alkaline size N batteries returned with a calculator, perform the following steps for each cell:

- a. Connect a 13-ohm, 5%, 1/4W resistor across the battery terminals.
- b. Measure the dc voltage across the load.
  - If the voltage is at least 1.1 Vdc, the cell is good.
  - If the voltage is less than 1.1 Vdc, the cell is bad.

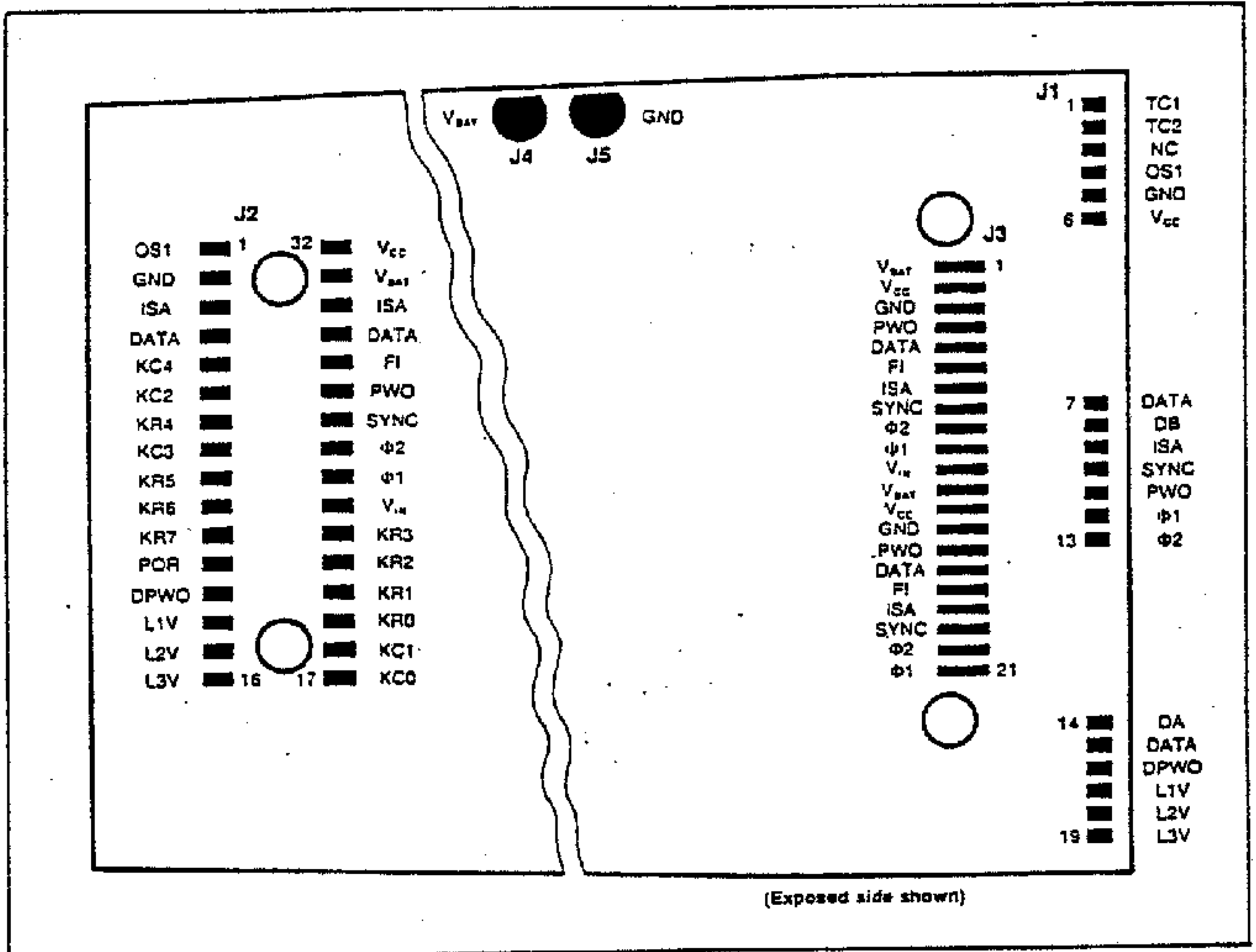

Figure 4-4. Contacts on Keyboard PC Board

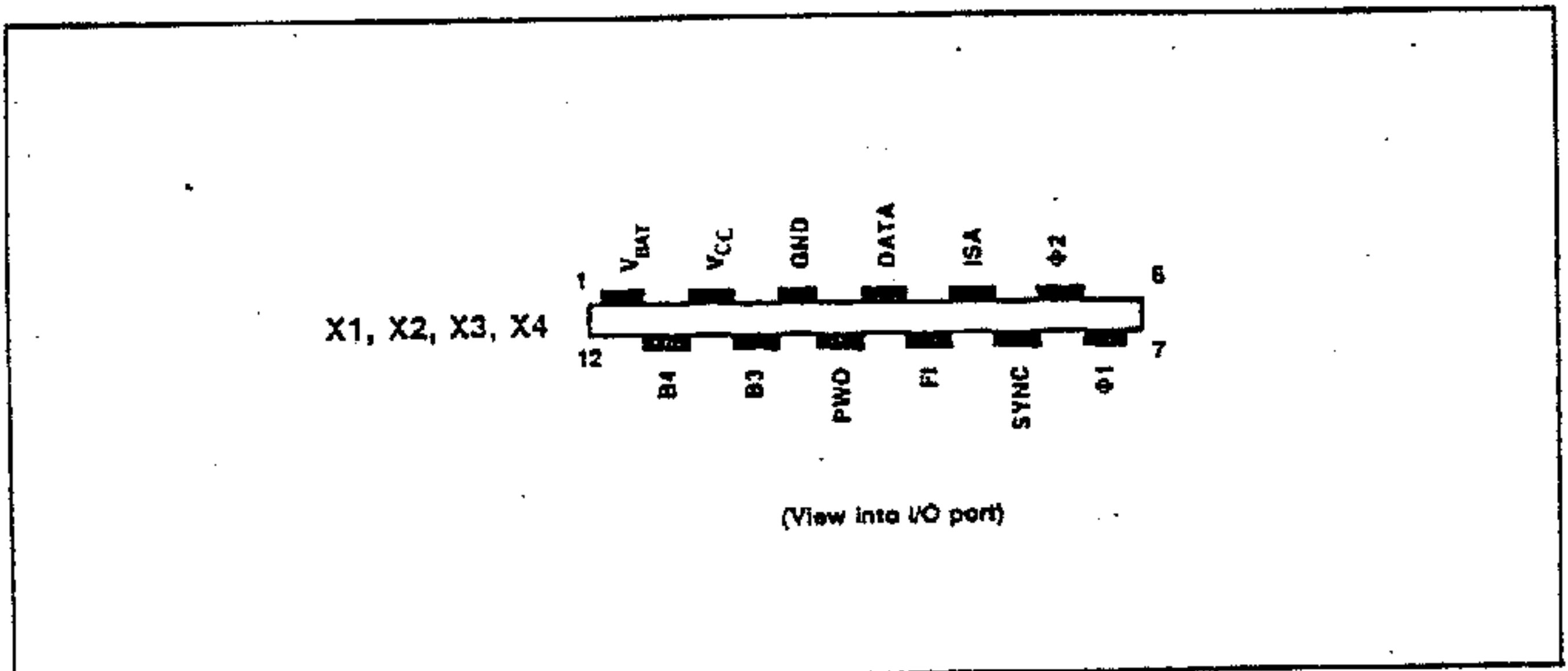

Figure 4-5. Contacts at I/O Port

Table 4-5. Logic PCA Replaceable Parts

REFERENCE DESIGNATION	HP PART NUMBER	DESCRIPTION	QTY
	00041-80001	BOARD, logic PC	1
C1	0180-2910	CAPACITOR, 470 $\mu$ F, 6V	1
C3	0180-2925	CAPACITOR, 82 $\mu$ F, 10V	1
C10	0180-2978 *	CAPACITOR, 33 $\mu$ F, 10V	1
C9	0180-0575	CAPACITOR, 2.2 $\mu$ F, 20%, 15V	1
C5	0160-0576	CAPACITOR, 0.1 $\mu$ F, 20%, 50V	1
C2, C8	0160-3914	CAPACITOR, 0.01 $\mu$ F, 10%	2
C4	0160-0687	CAPACITOR, 150 pF, 5%	1
C6	0160-3802	CAPACITOR, 150 pF, 10%	1
CR1, CR5	1901-0868 *	DIODE, Schottky	2
CR2, CR3, CR6, CR7	1901-1098	DIODE, switching	4
CR4	1902-0049	DIODE, zener, 6.19V, 5%	1
L1	9140-0238	INDUCTOR, 82 $\mu$ H, 5%	1
T1	9100-3594	INDUCTOR, toroidal, 1 mH	1
U2	1826-0566	INTEGRATED CIRCUIT, bipolar power supply	1
U1	1LA5-0001	INTEGRATED CIRCUIT, CPU	1
U6	1LA7-0001	INTEGRATED CIRCUIT, D/S 0	1
U7	1LA7-0002	INTEGRATED CIRCUIT, D/S 1	1
U8	1LA7-0003	INTEGRATED CIRCUIT, D/S 2	1
U9	1LA7-0004	INTEGRATED CIRCUIT, D/S 3	1
U10	1LA7-0005	INTEGRATED CIRCUIT, D/S 4	1
U3	1LA3-0015	INTEGRATED CIRCUIT, ROM 0	1
U4	1LA3-0016	INTEGRATED CIRCUIT, ROM 1	1
U5	1LA3-0022	INTEGRATED CIRCUIT, ROM 2	1
R1, R3	0698-7187 *	RESISTOR, 2M, 5%, 1/4W	2
R2	0698-6725	RESISTOR, 100K, 10%	1
R5	0698-5426 *	RESISTOR, 10K, 10%	1
R4	0698-6000 *	RESISTOR, 2.7K, 5%	1
	0460-1447	TAPE, foam	1
Y1	0960-0509	TRANSDUCER, piezo, alarm	1
Q1	1853-0020	TRANSISTOR, PNP	1
Q2	1854-0668	TRANSISTOR, NPN	1
Q3	1854-0092	TRANSISTOR, NPN	1

\* Other similar parts may have been substituted in early units.

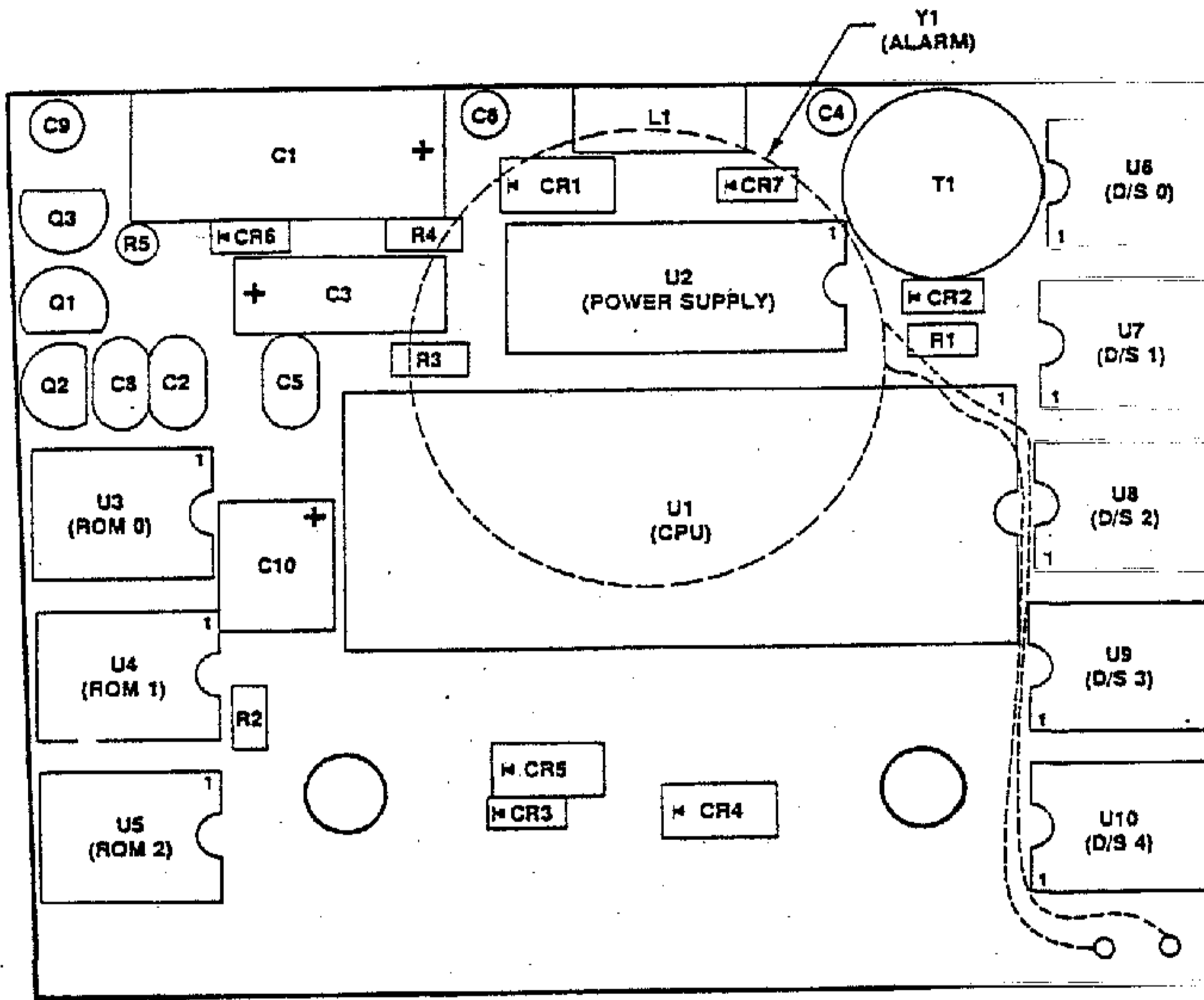
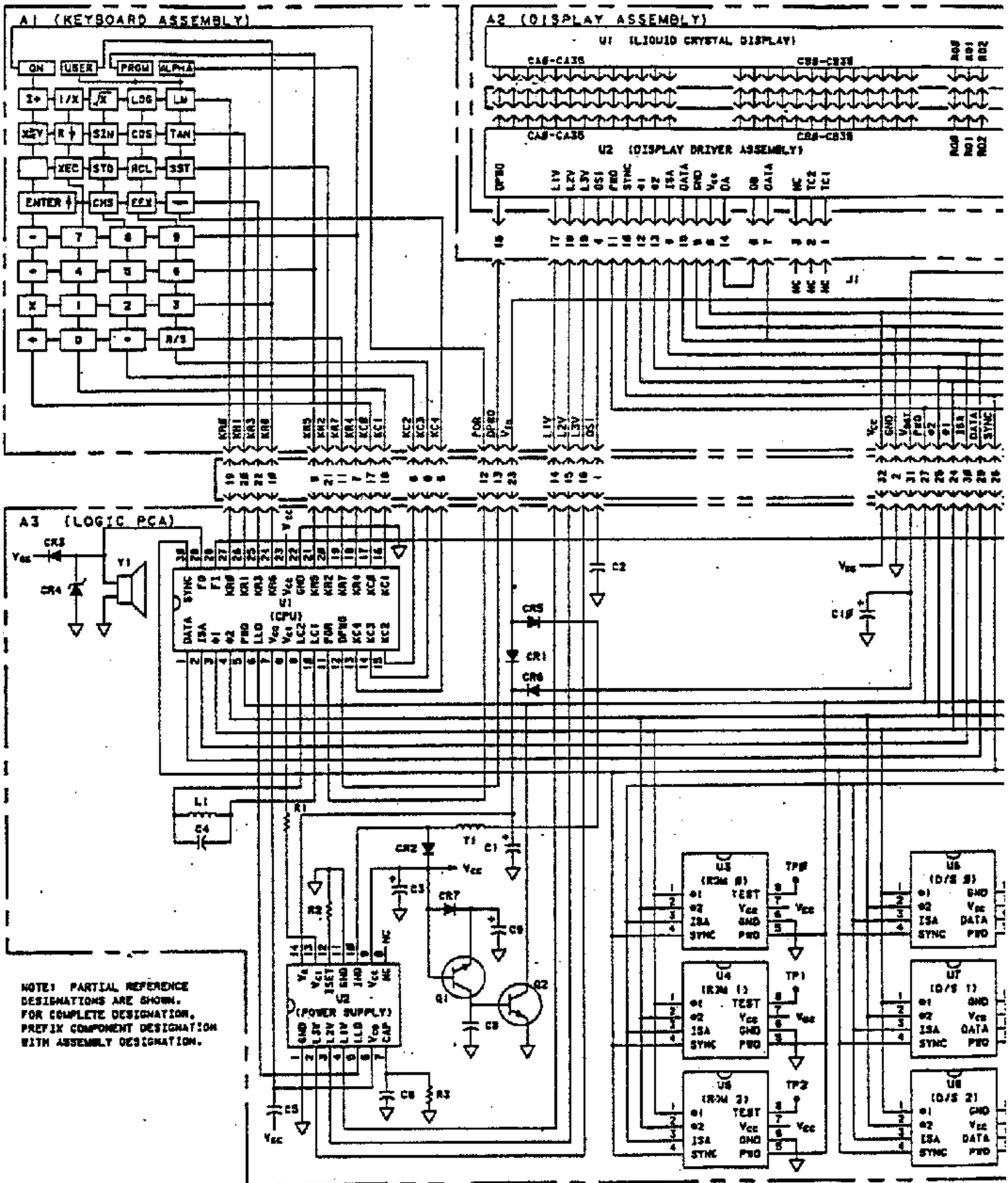

Figure 4-6. Component Location Diagram for Logic PCA



NOTE: PARTIAL REFERENCE DESIGNATIONS ARE SHOWN. FOR COMPLETE DESIGNATION, PREFIX COMPONENT DESIGNATION WITH ASSEMBLY DESIGNATION.

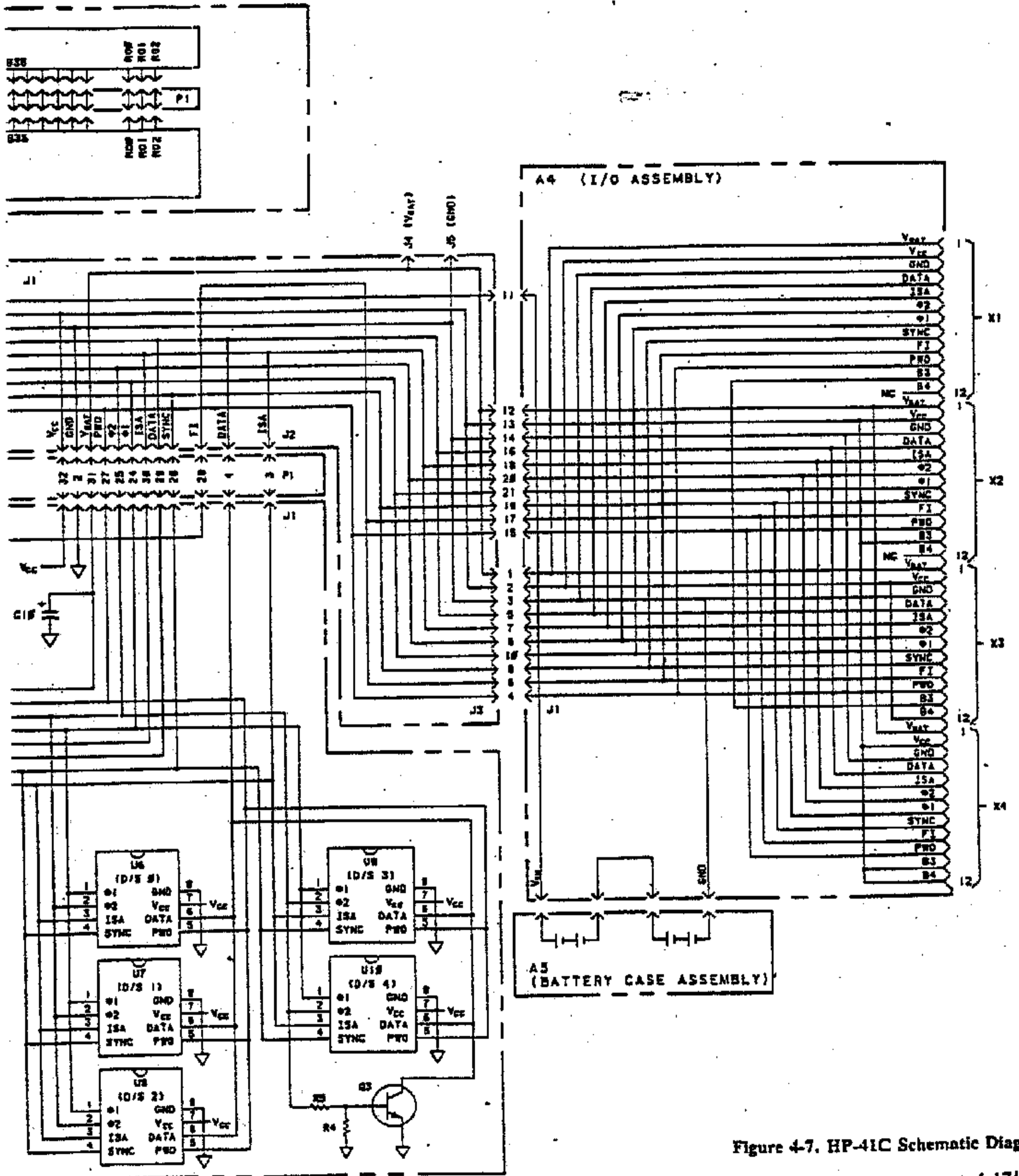

Figure 4-7. HP-41C Schematic Diagram



## Service Module

---

5-1. This section gives a summary of the capabilities of the plug-in service module, tool number ET-11966. It is intended as a reference only. *Do not* attempt to use it as a test procedure.

5-2. The plug-in service module is capable of performing diagnostic tests of essentially all portions of the HP-41C calculator. In addition, the module can test plug-in memory modules, application modules, and the HP 82104A Card Reader. It can also test itself. The

calculator's display is used to give a visual output of the diagnosis.

5-3. Table 5-1 summarizes the capabilities of the service module. Options, possible LCD displays, comments, and actions are described for each test. Refer to paragraph 4-7 for additional information about using the module. See figure 4-1 to determine key assignments for specifying particular tests.

Table 5-1. Summary of ET-11966 Service Module Operation

TEST	LCD DISPLAY	COMMENT	NEXT STEP
* CPU	CPU OK CPU BAD (blank)	Tested portion of CPU is good. Tested portion of CPU is bad. Calculator has undiagnosed malfunction.	<ul style="list-style-type: none"> <li>Press <b>[R/S]</b> for test selection, or press any test key.</li> <li>Press <b>[OFF]</b> to turn off the calculator.</li> <li>Remove batteries to turn off the calculator.</li> </ul>
Test Selection	SELECT TEST (AUTO)	Ready for test selection. Indicates selection of automatic operation.	Press any test key (manual operation), or press <b>[FWD]</b> or <b>[A/FWD]</b> to select automatic operation. Press any test key (automatic operation), or press <b>[R/S]</b> to cancel automatic operation.
† Display	SOME DIS BAD DRV/CPU BAD DISP DRY BAD  <pre> XXXXXXXXXX  3  4  5  6  7  8  9 XXXXXXXXXX           </pre>	Indicates improper DIS response. Display driver or CPU is bad. Display driver is bad.	<ul style="list-style-type: none"> <li>Press <b>[R/S]</b> for test selection, or press any test key.</li> <li>Press <b>[R/S]</b> for test selection, or press any test key.</li> <li>Press <b>[R/S]</b> for test selection, or press any test key.</li> </ul> <p>} Press and hold <b>[R/S]</b> to pause.</p>
† DIS	DIS TEST DIS OK DIS 0,2, BAD	Display during test. All DIS IC's are good. Indicated DIS IC's are bad.	Press <b>[R/S]</b> for test selection, or press any test key.
† ROM	ROM TEST ROM OK ROM 0,2, BAD	Display during test. All ROM IC's are good. Indicated ROM IC's are bad.	<ul style="list-style-type: none"> <li>Press <b>[R/S]</b> for test selection, or press any test key.</li> <li>Press <b>[R/S]</b> for test selection, or press any test key.</li> </ul>
‡ Keyboard	KYBOARD TEST KYBOARD OK KYBOARD BAD DOUBLE ENTER KYBD AGAIN?	Display during test. All keys registered in proper sequence. Key entered out of sequence or not registered properly. Noisy entry of a key. Message after test results (manual multiple mode).	<p>Press keys in order. Press <b>[R/S]</b> <b>[R/S]</b> to stop automatic operation, if selected.</p> <ul style="list-style-type: none"> <li>Press <b>[R/S]</b> for test selection, or press any test key.</li> <li>Press <b>[R/S]</b> <b>[R/S]</b> for test selection (for retest option in manual multiple mode).</li> <li>Press <b>[R/S]</b> <b>[R/S]</b> for test selection (for retest option in manual multiple mode).</li> <li>Press <b>[R/S]</b> or <b>[R/S]</b> to continue sequence, or press <b>[Y]</b>, <b>[E]</b>, or <b>[I]</b> to repeat test.</li> </ul>
‡ Standby	STANDBY TEST CPU BAD STANDBY OK MEM 1,2,LOST	Display during test. CPU is bad. Memory maintained in STANDBY mode. Contents of indicated IC's altered.	<ul style="list-style-type: none"> <li>Press <b>[R/S]</b> for any other key) to complete test.</li> <li>Press <b>[R/S]</b> for test selection, or press any test key.</li> <li>Press <b>[R/S]</b> for test selection, or press any test key.</li> <li>Press <b>[R/S]</b> for test selection, or press any test key.</li> </ul>
‡ Sleep	SLEEP TEST CPU BAD (blank) SLEEP OK MEM 0,2,LOST	Display at start of test. CPU is bad. Proper blank display in SLEEP mode. Memory maintained in SLEEP mode. Contents of indicated IC's altered.	<ul style="list-style-type: none"> <li>Press <b>[R/S]</b> for test selection, or press any test key.</li> <li>Press any key except <b>[R/S]</b> to verify no response. Then press <b>[R/S]</b> to complete test.</li> <li>Press <b>[R/S]</b> for test selection, or press any test key.</li> <li>Press <b>[R/S]</b> for test selection, or press any test key.</li> </ul>
‡ Multiple Summary	ALL TESTS OK ERROR 3,6,	All tests in multiple sequence were passed. Indicated tests in multiple sequence not passed: 11 = Display, 2 = DIS, 3 = ROM, 4 = Keyboard, 5 = Standby, 6 = Sleep.	Press <b>[R/S]</b> for test selection, or press any test key. Press <b>[R/S]</b> for test selection, or press any test key.
Character	<pre> CPU OK DIS OK ROM OK KYBD OK SLEEP OK MEM OK           </pre>	Displays for evaluating character structure.	} Press and hold <b>[R/S]</b> to pause.



ATUO AGAIN?	ALWAYS ALLOC TEST RESULTS (WARRANT MULTIPLE MODES)	Press (L) or (R/S) to continue sequence, or press (L), (R/S), or (R/S) to repeat test.
Standby	Display during test. CPU is bad. Memory maintained in STANDBY mode. Contents of indicated IC's altered.	Press (R/S) (or any other key) to complete test. Press (R/S) for test selection, or press any test key. Press (R/S) for test selection, or press any test key. Press (R/S) for test selection, or press any test key.
Sleep	Display at start of test. CPU is bad. Proper Mem'd display in SLEEP mode. Memory maintained in SLEEP mode. Contents of indicated IC's altered.	Press (R/S) for test selection, or press any test key. Press any key except (R/S) to verify no response. Then press (R/S) to complete test. Press (R/S) for test selection, or press any test key. Press (R/S) for test selection, or press any test key.
Multiple Summary	All tests in multiple sequence were passed. Indicated tests in multiple sequence not passed: 11 = Display, 2 = DVS, 3 = ROM, 4 = Keyboard, 5 = Standby, 8 = Sleep.	Press (R/S) for test selection, or press any test key. Press (R/S) for test selection, or press any test key.
Character	Displays for evaluating character structure.	Press and hold (R/S) to pause.
Keypcode	Display at start of test. Row and number of pressed key. Noisy entry of a key. Invalid row or key number generated by CPU.	Press (R/S) for test selection, otherwise continue testing. Press (R/S) for test selection, otherwise continue testing. Press (R/S) for test selection, otherwise continue testing.
ROM ID Check	Internal ROM's have indicated revisions.	Press (R/S) for test selection, or press any test key.
I/O Port	Display during test. I/O ports are good for lines tested. Indicated function or ports do not respond properly.	Press (R/S) for test selection, or press any test key. Press (R/S) for test selection, or press any test key.
Debounce	Display during test. All keys registered in proper sequence. Key entered out of sequence or not registered properly. Noisy entry of key.	Press keys in order. Press (R/S) (R/S) to stop subsequent operations. If selected. Press (R/S) for test selection, or press any test key. Press (R/S) (R/S) for test selection. Press (R/S) (R/S) for test selection.
Memory Module	Display at start of test. Proper blank display in SLEEP mode (manual operation). Memory module is good. Memory module is bad. Memory module is bad.	Press (R/S) to complete test. Press (R/S) for test selection, or press any test key. Press (R/S) for test selection, or press any test key. Press (R/S) for test selection, or press any test key.
Application Module 1	Display during test. Application module is good. Application module is bad.	Press (R/S) for test selection, or press any test key. Press (R/S) for test selection, or press any test key.
Application Module 2	Display during test. Application module is good. Application module is bad.	Press (R/S) for test selection, or press any test key. Press (R/S) for test selection, or press any test key.
Application Module ID	ID, revisions for good single-chip module. ID's, revisions for good double-chip module.	Press (R/S) for test selection, or press any test key. Press (R/S) for test selection, or press any test key.
Quality Assurance (Card Reader)	Display at start of test. Display during first part of test. ROM IC is bad. CRC IC is bad. Operating instructions. Detected clipped corner on card. Head switch not working properly. Card insert switch not working properly. Micro speed in control. Operating instructions.	Press (R/S) for test selection, or press any test key. Press (R/S) for test selection, or press any test key. Insert clipped card into slot. Press (R/S) for test selection, or press any test key. Press (R/S) for test selection, or press any test key. Insert blank, unclipped card into slot.

<p>BLANK CARD SAME CARD WRITE/READ O. K. WRITE/READ ERR NO DATA</p>	<p>Operating instruction. Operating instruction. Write and read operations work properly. Write or read operation is faulty. No data detected on card.</p>	<p>Insert blank, unclipped card into slot. Reinsert card from previous step. Insert blank card to repeat, or press [F7] for test selection. Insert blank card to repeat, or press [F7] for test selection.</p>
<p>CR ATR TEST CRC BAD SPD - 102 PROTECTED HD SWITCH BAD CI SWITCH BAD</p>	<p>Display at start of test. CRC IC is bad. Motor speed is correct. Detected clipped corner on card. Head switch not working properly. Card insert switch not working properly.</p>	<p>Insert card into slot. Press [F7] for test selection, or press any test key. Insert card to repeat, or press [F7] for test selection. Press [F7] for test selection, or press any test key. Press [F7] for test selection, or press any test key. Insert blank card into slot, or press [F7] for test selection.</p>
<p>CR WRITE CRC BAD BLANK CARD PROTECTED</p>	<p>Display at start of test. CRC IC is bad. Operating instruction. Detected clipped corner on card.</p>	<p>Press [F7] for test selection, or press any test key. Insert card from Write Mode, or press [F7] for test selection.</p>
<p>CR READ TEST CRC BAD SAME CARD READ O. K. READ ERR NO DATA HD SWITCH BAD</p>	<p>Display at start of test. CRC IC is bad. Operating instruction. Read operation works properly. Read operation is faulty. No data detected on card. Head switch not working properly.</p>	<p>Press [F7] for test selection, or press any test key. Insert card into slot, or press any test key.</p>
<p>CR BUF TEST CRC BAD SPD 02% SLOW SPD 01% FAST SPD TOO SLOW SPD TOO FAST SPD UNSTABLE NO DATA HD SWITCH BAD CI SWITCH BAD</p>	<p>Display at start of test. CRC IC is bad. Relative motor speed. Relative motor speed. Motor speed more than 20 percent slow. Motor speed more than 20 percent fast. Motor speed not consistent. No data detected on card. Head switch not working properly. Card insert switch not working properly.</p>	<p>Insert recorded card into slot. Press [F7] for test selection, or press any test key. Insert recorded card to repeat, or press [F7] for test selection. Insert recorded card to repeat, or press [F7] for test selection. Insert recorded card to repeat, or press [F7] for test selection. Insert recorded card to repeat, or press [F7] for test selection. Insert recorded card to repeat, or press [F7] for test selection. Press [F7] for test selection, or press any test key. Press [F7] for test selection, or press any test key.</p>
<p>SRY MOD TEST SM-1:A OK SRY MOD BAD</p>	<p>Display during test. Service module is good. Service module is bad.</p>	<p>Press [F7] for test selection, or press any test key. Press [F7] for test selection, or press any test key.</p>

\* This test is included in the multiple test sequence only during automatic operation.

† This test is included in the multiple test sequence.

‡ This test is included in the multiple test sequence only during manual operation.

Note: Press [F7] at any time during testing to turn off the calculator at the end of the test section, with three exceptions: during the keyboard test, during the sleep test, and during the keycodes test.

## Replaceable Parts

---

### 6-1. INTRODUCTION

6-2. This section contains information pertaining to the parts used in the HP-41C, illustrated in figure 6-1. Parts descriptions, quantities, HP stock numbers, reference designations (where applicable) and assembly breakdowns are given. (Refer to table 6-1.)

6-3. Replaceable parts for the logic PCA (table 4-5) are listed for convenience alongside its component location diagram in section IV.

### 6-4. ORDERING INFORMATION

6-5. To order replacement parts or assemblies, address order or inquiry to Corporate Parts Center or Parts Center Europe. Specify the following information for each part ordered:

- a. Calculator model and serial number.
- b. HP part number.
- c. Description.
- d. Complete reference designation (if applicable).

Table 6-1. HP-41C Replaceable Parts

INDEX NUMBER, FIGURE 6-1	HP PART NUMBER	DESCRIPTION	QTY
1	00041-60009	ASSEMBLY, battery case (A5)	1
	00041-40005	• CASE, battery	1
	00041-00009	• KEEPER, battery	2
	1460-1695	• SPRING, battery	2
2	00041-60005	ASSEMBLY, display (A2)	1
	00041-60090	• ASSEMBLY, display driver (A2U2)	1
	1600-0825	• CLIP, display	2
	1251-5400	• CONNECTOR, display (A2P1)	2
	1PT1-0001	• DISPLAY, liquid crystal (LCD) (A2U1)	1
	0340-0919	• INSULATOR, display	2
	00041-40065	• LOCATOR, display	1
	0460-1176	• TAPE, adhesive transfer	
	00041-60001	ASSEMBLY, logic PC (A3)	1
	00041-60008	ASSEMBLY, I/O (A4)	1
5	00041-60907	ASSEMBLY, keyboard, service (A1)	1
6	00041-20002	BALL, ac contact	2
7	00041-40002	CASE, bottom	1
8	00041-40006	CASE, center	1
9	1251-5731	CONNECTOR, logic (P2)	1
10	00041-40025	COVER, ac tunnel	1
11	4040-1522	COVER, battery recess	1
12	00041-40007	DOOR, I/O blank	4
13	0403-0279	FOOT, rubber	4
14	7220-8153	LABEL, logo	1
15	7220-8154	LABEL, alpha	1
16	2740-0014	NUT, hex	2
	2740-0013	NUT, hex (undersized)	
17	00041-40067	RETAINER, ac contact	1
18	0624-0435	SCREW, 0.25-inch	2
19	0624-0432	SCREW, 0.75-inch	2
	0624-0436	SCREW, 0.38-inch (oversized)	
20	00041-40064	SHIELD, display	1
21	1460-1767	SPRING, ac contact	2

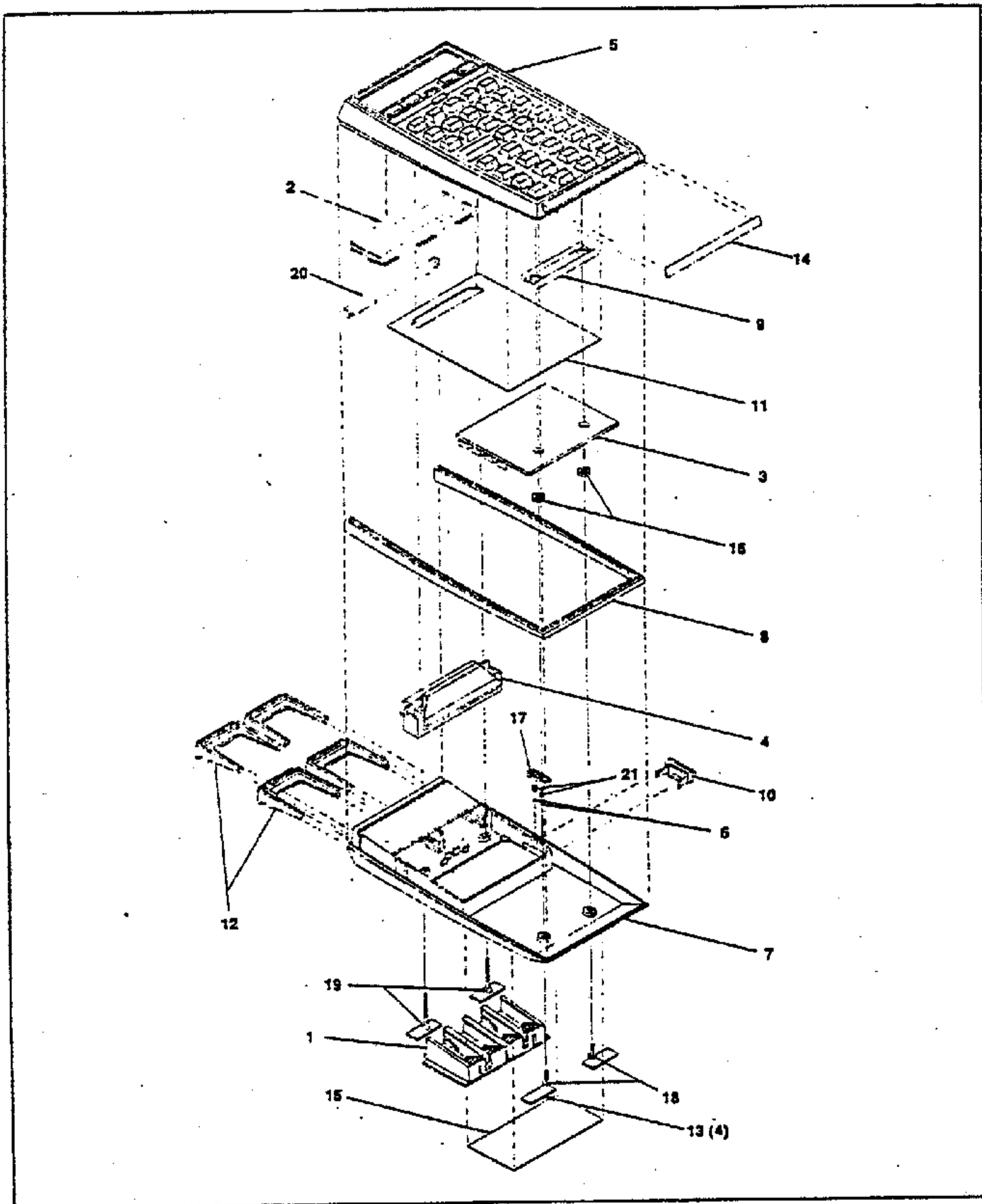

Figure 6-1. HP-41C Exploded View



# Memory/Application Module Test

## A-1. INTRODUCTION

A-2. This appendix contains information necessary to test HP-41C style memory modules and application modules. These modules are *not* repairable. A module should be *replaced* if it is defective.

## A-3. DESCRIPTION

A-4. Memory and application modules compatible with the HP-41C style calculator are designed to expand the capabilities of the calculator system. They interface with the calculator through its input/output ports, which electrically connect the CMOS hybrid IC's in the modules directly to the main system lines. Specifications for the modules are presented in table A-1.

A-5. Each HP 82106A Memory Module contains 64 registers of data memory, which can accommodate 448 bytes of program memory. The modules become part of the calculator's continuous memory.

A-6. Each plug-in application module contains up to 40K or 80K bits of microprogrammed memory. A maximum of 32 different versions may be available.

A-7. The memory and application modules operate as an extension of the calculator's D/S and ROM capabilities. Their interaction with the calculator system is identical to that of the main D/S and ROM IC's.

## A-8. IDENTIFICATION

A-9. The serial number of the memory module or application module is used for determination of warranty status. It is located on the bottom of the module below the label. Its format is described below:

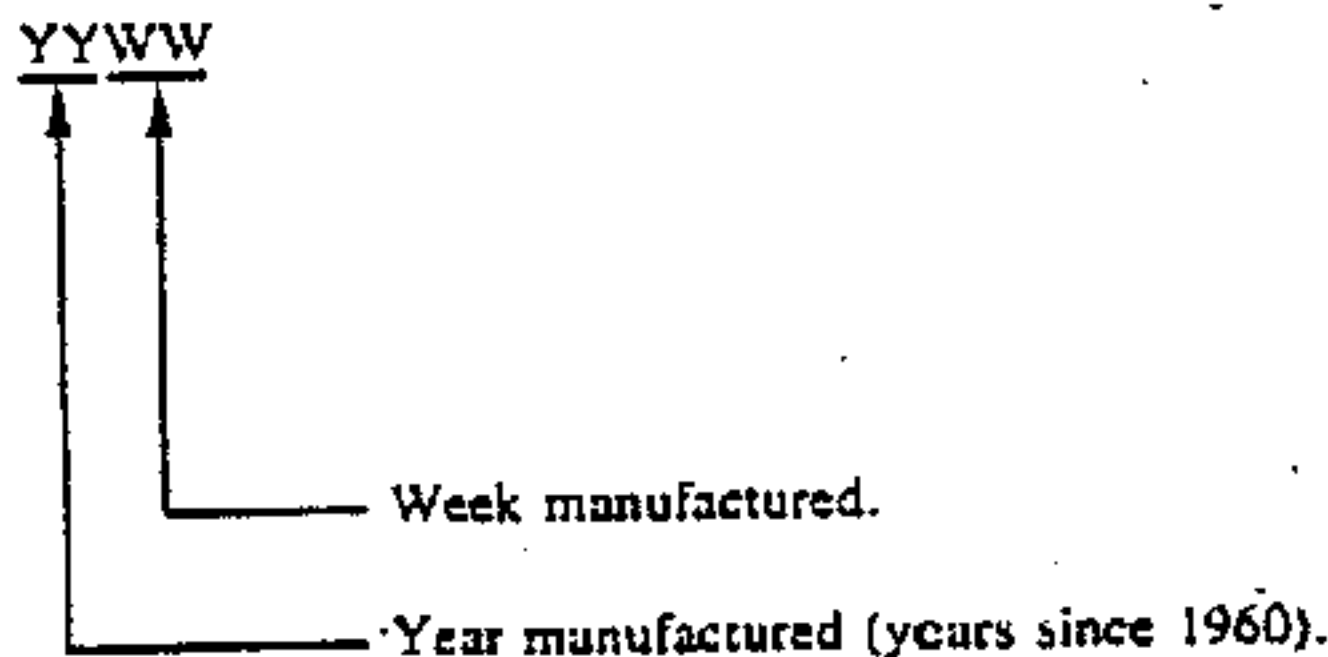

Table A-1. Module Specifications

Physical Properties	
•	Length: 3.12 centimeters (1.23 inches).
•	Width: 2.95 centimeters (1.16 inches).
•	Height: 0.89 centimeters (0.35 inches).
•	Weight: 5.9 grams (0.21 ounces).
Compatibility	
•	Plugs into HP-41C style calculator.
•	Power supplied by the calculator.
Temperature	
•	Operating: 0° to 45° C (32° to 113° F).
•	Storage: -20° to 65° C (-4° to 149° F).

## A-10. DIAGNOSTIC TEST

A-11. Test a memory module or application module by performing the following procedures and observing the indicated displays. For each step or condition that can occur, the resulting LCD display on the test calculator is shown at the right.

**Note:** Do not operate the test calculator on batteries for an extended period of time with the service module plugged in. This module prevents the system from switching to a low-power mode and can cause excessive battery drain.

**1 Preparation**

- a. Be sure that the test calculator is off. If the display is active, press the **ON** key to turn it off.
- b. Insert the service module in the lower left (#3) I/O port. Do not insert any modules while the calculator is turned on.
- c. Insert the memory module or application module in the lower right (#4) I/O port.
- d. Insert two good memory modules in the upper I/O ports.
- e. Press the **ON** key to turn on the calculator and start the diagnostic test. Watch for:
  - A triple beep and this blinking LCD display indicate that the test calculator is operating properly. (The message **CPU OK** may appear momentarily in the display.)
  - Any other outcome indicates improper operation. In this case, turn the calculator off, remove the memory or application module, and turn the calculator on again. If the proper outcome (above) occurs, the removed module is bad; otherwise, the test calculator or service module is bad.

**SELECT TEST**

**2 Application Module Tests**

After the initial preparation (procedure 1), perform these steps to test an application module located in the lower right (#4) I/O port:

- a. Press the **SST** key to select the single-IC application module test. Most application modules contain only one ROM IC. If the module has two ROM IC's, press the **□** key to select the double-IC application module test. Watch for:
  - The flag annunciators indicate which IC is being tested (1 or 2).
  - Either of these LCD messages indicate that the application module is good.
  - Either of these LCD messages indicate that the application module is bad. Proceed to step c.
- b. Press the **ENTER** key to select the application module identification check. The two letters and number in each identification represent the particular application pac; the following letter represents the revision. Watch for:
  - This type of LCD display indicates the identification for a good single-IC module.
  - This type of LCD display indicates the identifications for a good double-IC module.
  - Any other display (especially one containing @'s or 0's) indicates a bad module.
- c. Press the **ON** key to turn off the calculator, completing the test.

**AP1 MOD TEST**  
**AP2 MOD TEST**

**AP1 MOD OK**  
**AP2 MOD OK**  
**AP1 MOD BAD**  
**AP2 MOD BAD**

**MA-1B**

**ST-1B ST-1A**